



COACHMAN

2026

HANDBOOK & TECHNICAL DATA





INTRODUCTION

All Coachman models have been certified by the National Caravan Council for compliance with stringent European Standards, British Legislation and industry set Codes of Practice, specifically

relating to health and safety issues. The approval process covers the testing and inspection of critical areas of the product from fire safety, weights and dimensions to gas, electrics and ventilation.



COACHMAN

Not all equipment described is fitted to every derivative. To check your individual specification please check with the brochures and your dealer or visit the Coachman website (www.coachman.co.uk)

All the illustrations and descriptive matter in this guide are intended to give a general idea of the caravan. Changing market and supply situations may prevent us from maintaining exact specification details in this guide and we therefore reserve the right to alter specifications as materials and conditions demand.

Please check current details with your dealer and inspect the caravan to ensure it is satisfactory before purchase. Dealers are not agents and have absolutely no authority to bind Coachman Caravan Company Limited by any express or implied undertaking or representation.

Introduction	1	Aventa Air Conditioning Unit	71
Your Caravan	4	Refrigerator	81
Security	7	Oven, Hob & Grill	100
Fitment of AL-KO Secure	8	Microwave	114
Towing Code	11	Smoke Alarm & CO2 Alarm	115
Preparing for the Road	16	Toilet	121
Pre-Tow Checklist	17	Rooflights	126
Coupling-Up Checklist	28	Omnivent	127
Towing & Driving	28	Micro, Midi & Mini Heki	129
Caravan Handling	28	Television Aerial	133
Reversing	29	Security Alarm System	136
Changing a Wheel	29	Care of your Caravan	143
Safety & Security	31	Beds & Bunks	143
Arrival at Site	32	Cleaning	144
Connecting Services	35	Storage	152
Water	35	Maintenance	154
Gas	40	AL-KO Chassis	154
Electricity	44	Servicing	158
Control Panel	53	Warranty	159
Caravan Equipment	64	Technical Data	160
Alde Heating/Water System	64		

Introduction

Welcome to the world of caravans

You are now the owner of a Coachman caravan. The User's Guide has been prepared for your guidance to help you derive the greatest amount of pleasure from the use of your caravan. It is recommended that you read the pages of this guide thoroughly so that you are fully conversant with all the caravan systems. The major proprietary components of the caravan such as the chassis, heater, oven, water heater, refrigerator and electrical control systems all have their own comprehensive operating instructions which should be supplied with your caravan. It is strongly recommended that you read these too as it is not possible to include all the information they contain in this handbook.

Your caravan is covered by a 3 year warranty. **To activate this warranty your selling dealer must complete with you the online warranty registration at the time of collection.**

Towing vehicles

When selecting a towing vehicle for your caravan we strongly recommend you check the NCC website "Towcheck" www.towcheck.co.uk to ensure your car and touring caravan towing combination is safe and legal.

Repairs

If you damage your caravan or it should require repairing for any reason, please contact your supplying dealer. These repairs must be carried out by an authorised dealer or approved servicing centre using Coachman genuine parts, recommended sealant and following Coachman procedures.

All Coachman caravans are classed as portable and therefore all warranty work requires the caravan to be delivered and collected from the supplying dealer or approved servicing centre. The cost of transporting, towing or moving the caravan to and from the place of repair is

the responsibility of the owner.

NOTE: Caravan Movers

Any caravan mover fitted shall comply with the design, fitment and safety requirements of NCC Code of Practice 305. The installation of a caravan mover shall be in accordance with the motor mover manufacturer's installation instructions.

You should ensure you receive a signed installation certificate of compliance from the installer. Failure to do so may invalidate your warranty.

NOTE: Self Levelling Systems

Any self-levelling system fitted shall comply with the design, fitment and safety requirements of the NCC Code of Practice 308. The installation of the self-levelling system shall be in accordance with the self-levelling system manufacturers installation instructions.

You should ensure you receive a signed installation certificate of compliance from the installer. Failure to do so may invalidate your warranty.

Fitment of additional equipment

Where additional equipment is intended to be fitted to your vehicle, this equipment will not be covered by the Coachman warranty. Examples of such equipment are satellite dishes, extending awnings and additional solar panel(s). Where this additional equipment, in its fitment, has to puncture the vehicle outer surface, then advice should be sought from Coachman with regards to placement of these holes. If an item is to be bonded to the vehicle, advice should be sought from Coachman with regards to positioning this equipment to existing bonded joints (so as to not put additional undue stress on the existing joints), and the type of adhesive to be used. Coachman will not accept any warranty claims from water ingress caused by the fitment of any additional equipment.

Fire retardant foams

Under the condition of the Consumer Protection Act 1987, the manufacturer

has a responsibility to ensure that their product is as safe as possible.

With this in mind all caravans are equipped with either Combustion Modified High Resilient (C.M.H.R.) foam cushions or sprung mattresses. (These foams are much safer from a fire point of view than those previously used. In addition all upholstery is made of fire retardant fabric.)

NOTE: Whilst this manual will describe the general operation of the caravan, we recommend that you refer to the individual equipment manufacturers manuals for detailed information.

CRIS registration and VIN chip**Caravan Registration**

This caravan has been security marked and recorded under the Caravan Registration and Identification Scheme that is recognised by the Caravan Industry.

Shortly after purchasing this caravan you should receive your Touring Caravan

Your caravan

Registration Document. It will be sent by post to your home address.

Your Touring Caravan Registration Document will include a 17 character VIN (Vehicle Identification Number), shown in the top right hand corner. This 17 character VIN will be permanently marked onto the caravan chassis.

To protect yourself and your touring caravan, never leave the Registration Document in the caravan. For security reasons keep it in a safe place.

If you sell the caravan please follow the instructions on the touring caravan registration document.

If you do not receive a touring caravan registration document, lose it, or any of the details recorded are incorrect, please contact:

CRiS

Catherine House, 74-76 Victoria Road,
Aldershot, Hampshire, GU11 1SS
or tel: 0203 282 1000

VIN Chip Caravan Identification

The caravan's unique 17 character VIN will be incorporated into VIN Chip tamper evident labels; the master VIN Chip label is situated on the front nearside window to aid police checking, another in the gas locker and a maximum of 10 placed on the inside of all windows (with the exception of opaque windows).

Three electronic RFID chips containing the individual identity of your caravan are concealed within the caravan and can only be read by using a specially programmed RFID scanner.

Your local police can obtain the use of a **CRiS VIN Chip scanner by contacting CRiS on Tel 0203 282 1000.**

Window Lozenge



Master Window Label

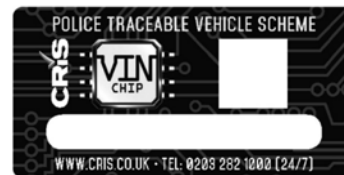

Gas Bottle Locker Warning Label



Alarm and tracking (where fitted)

A security system developed by Phantom for leisure vehicle security.

It's the complete insurance rated alarm and the latest Phantom Pro3 GPS system, not only protecting your caravan but bringing the ability to monitor and control remotely.

Never again will you wonder if you set the alarm. A simple secure app will show you the alarm status and allow you to arm or disarm the alarm from wherever you are.

My Phantom your portal

The unique portal providing online access to monitor your caravan. Login via the Phantom website or download our app on Android or Apple. You'll be able to check your location and battery voltage as well as setting service mode. Caravan information and your individual Phantom Tracking device number.

Displays the location of your vehicle which updates each time you move or every 6 hours if stationary.

The portal will let you know when your subscription ends and when it started.

Your mileage history graph will give you readings linked to the ignition. If you have a caravan then these readings are calculated using our GPS data and can be less accurate.

Reports monitor and store the voltage of the leisure battery which is being used to power the Phantom tracking unit for 30 days. This enables you to spot possible issues with power drains, solar panel effectiveness and predict when your battery may need to be recharged.

Your battery dial, displays the current voltage.

Online support

You can submit a support request on our online system. You can monitor all chat responses and view your whole conversation.

Phantom our app

Visit the Apple Appstore or Google Play Store to download the Phantom App where you can:

a) Overview

Overview is your account information, the date your subscriptions end, and caravan info etc.

b) View

View your caravan location.

c) Reports

View the mileage history and battery history of your caravan where applicable.

d) Service

1. Temporarily disable power or alarm alerts.
2. Place your caravan into service mode for a period of time.
3. Select which alerts you wish to disable.

e) Viewers

Manage who can see your caravan's location. Friends and family if you want them to monitor your vehicles.

Alarm

Your alarm is connected to the tracking system. We notify you via a call if the alarm goes off. You can arm and disarm the alarm from the app.

Your caravan

Shield

The shield function can be used to alert users to movement of the caravan, which can be easily enabled or disabled.

Please note:

- 1) You must enable notifications for this to work.
- 2) Shield only sends a notification to any devices that are logged into the myphantom app.

It does not send an alert to the call centre.

On Android go into apps and select your app. It should give you notifications options.

24-7 monitoring of your caravan

Phantom systems are designed exclusively with caravanners in mind, providing features now and in the future to match any tracking needs.

The 'Pro3' checks into Phantom's central server twice a day, every day. It reports

its position and battery level as well as recording any mileage travelled. It has a unique sim card allowing it to utilise any network, providing unrivalled communications across the UK and over 28 European countries.

All this information is accessed through our online portal or Android 'App' and Apple App.

You or your family can check where the van is and its current battery level as well as a historical 30 day graph of voltage levels - great for keeping your eye open for any unexpected events. This will also help ensure longer battery life by showing users when their battery needs charging.

Text and phone calls confirm any alerts or power cuts.

More information is available from www.myphantom.uk.net

Security

VIN (Vehicle Identification Number)

Record your caravan VIN which can be found stamped on the underside of the drawbar or on one of the eye level windows. Make a note of this number in the space provided at the front of this guide and make a separate note of the number to keep safe at home.

Caravan theft

The theft of a caravan can occur in the most unlikely circumstances; from a motorway service area, even from an owner's driveway.

Secure all windows and doors when your caravan is unoccupied, even if only for a short length of time.

Additional security

Some models come as standard with the AL-KO Secure wheel clamping device. While some models have the AL-KO Secure receiver fitted as standard or the AL-KO Secure device can be purchased from your dealer if not supplied. Alternatively consider fitting any device which might deter or prevent intrusion



by thieves. A hitch lock cover prevents towing of the caravan.

Fitment of AL-KO Secure

- Align the wheel so that the receiver can be seen in the centre of the rim opening. **DO NOT** use the rim opening in which the tyre valve is fitted. **(Fig 1)**
- Unscrew the plastic cap from the receiver and store in the tool kit box. (When AL-KO Secure is not in use, always screw the plastic cap in place.) **(Fig 2)**
- Insert the locking bolt into the rim specific insert. **(Fig 3)**
- Insert the locking bolt socket key. **(Fig 4)**
- Line up the locking bolts and assembly with the receiver. **(Fig 5)**
- Tighten the locking bolt socket using the wheel spanner provided (or torque wrench as shown) to wheel torque (ideally 86 Nm). **(Fig 6)**

Fig.1



Fig.2

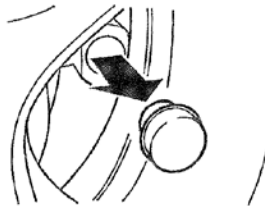

Fig.3

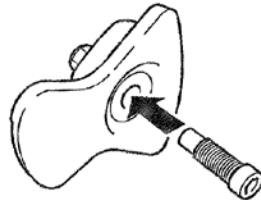

Fig.4

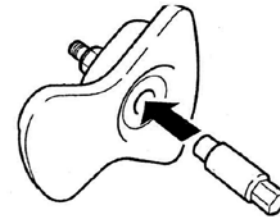

Fig.5



Fig.6



Your caravan

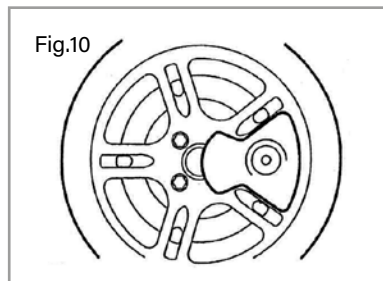
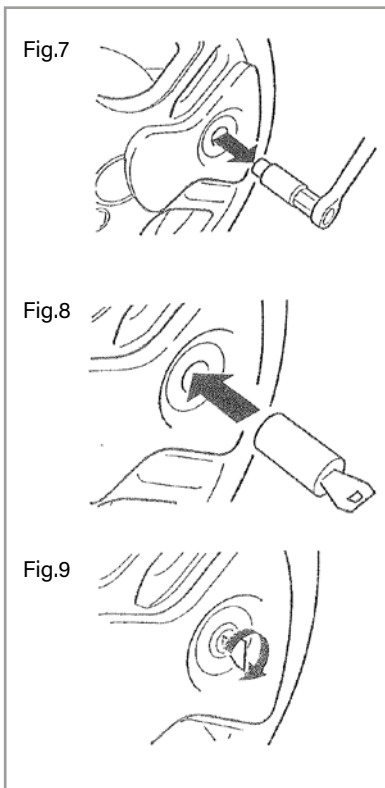

- Remove the locking bolt socket key. **(Fig 7)**
- Insert barrel lock. **(Fig 8)**
- Hold the lock fast and lock. **(Fig 9)**
- The AL-KO Secure is now fitted. **(Fig 10)**

Twin axle caravans

Fit the front lock first by aligning the wheel so the receiver can be seen in the centre of the rim opening. Chock front wheel and opposite wheel. Jack the caravan (preferably using the AL-KO side lift jack) until the rear wheel is clear of the ground. Fit the second lock by aligning

the wheel as described previously.

Free crime prevention

Advice on securing your caravan, protecting your valuables, property marking, either at home or whilst on site, can be obtained from the Crime Prevention Officer through your local Police Station.

AL-KO galvanised chassis

The AL-KO chassis fitted to your Coachman is constructed from high quality, hot dip galvanised steel.

The axles and suspension are comprised of 3 rubber elements within a hexagonal tube. Additional AL-KO Octagon Shock Absorbers are fitted as standard for increased damping and improved road holding.

Warning

Holes must not be drilled into the chassis. When purchasing a stabiliser or other equipment, consult your dealer who will advise you.

Braking system

The braking system comprises a rod operated overrunning device with expander mechanism and adjuster box.

An automatic reversing system with a spring-loaded reverse lever is attached to the adjuster box.

The system also incorporates a link device, which gives added safety to the handbrake operation when parking on a reverse slope or steep hill. Brake adjustment should be carried out by your dealer.



Body shell

Coachman caravans are manufactured using Advanced Bonding Construction. The bodies are made from the highest quality materials. The floor is constructed from a styrofoam plywood sandwich impregnated with anti-damp and rot compounds and adhesives. The roof is bonded but to maximise integrity it has a floating outer aluminium skin which allows it to expand and contract under climatic conditions without putting excessive pressure on the front, side and rear joints.

Under some conditions the roof may appear rippled. This is not detrimental to the bonding process, and allows natural expansion and contraction of the vehicle structure.

The wall comprises an insulated foam sandwich having a pre-coated aluminium exterior surface and a coated plywood interior finish. Framing is positioned within the sandwich to add strength.

The very latest 'state of the art' presses are employed to produce the extremely well insulated, robust, yet lightweight sections.

Windows are all of a dual glazed acrylic construction and the door frames are extruded aluminium. Fronts and backs are moulded acrylic capped ABS construction for strength and lightness.

Each caravan is fitted, as standard with an awning channel as an integral part of the aluminium roof and body side moulding. If it is found necessary to fit additional attachments, care must be taken to ensure any holes that are drilled in the outside of the body are correctly sealed (this should be carried out only by an approved dealership).

Awnings which employ rubber sucker or Pole Pad attachments rather than screw fixings are recommended.

On NO account should screws be permitted to enter the shell sandwich (from inside).

Towing code

All Coachman caravans are classified as Grade 3 thermal insulation.

This means that with an outside temperature of -15°C the internal temperature can be raised to 20°C within 4 hours of starting the heating.

Exterior doors

Your Coachman caravan is fitted with a Holzhauer one piece exterior door.

Firstly and most importantly, the door must not be slammed.

When closing the door from the outside, the handle should be pulled and the door pushed to with one hand. With the other hand, pressure should be applied to the front of the handle surround then the handle should be released and you will hear a click. This indicates that the door is shut.

When closing the door from the inside, you should move the lever down, pull the door closed firmly then release the lever.

Towing Code

Driving licence entitlement

It is strongly recommended that you check your driving licence entitlement to make sure you are legal and safe to drive.

Payloads for UK Touring Caravans

The Code of Practice has been prepared by the National Caravan Council and formulated with input from industry experts. The Code of Practice applies to UK specification touring caravans and applies for NCC certification to 2012 VIN onwards touring caravans.

The Code of Practice provides for the requirements for European Whole Vehicle Type Approval EWVTA, (The Framework Directive) and the directives referenced therein.

Please take care to ensure that you have allowed for the masses of all items you intend to carry in the caravan e.g. optional equipment and personal effects such as clothing, food, pets, bicycles, sailboards, sports equipment etc.

Definition of terms

Maximum Technically Permissible Laden Mass (MTPLM) lower limit

The fully laden mass of the caravan in the manufacturer's standard specification which enables the caravan to be matched to a wider range of towing vehicles.



NOTE:

A weight plate upgrade can be requested to the 'upper MTPLM' by the original owner of the caravan and within the first 12 months of ownership.

Maximum Technically Permissible Laden Mass (MTPLM) upper limit

This mass takes into account specific operating conditions including factors such as the strength of the materials, load capacity of the tyres, etc. This mass must not be exceeded.

Warning

Under no circumstances should the maximum technically permissible laden mass (MTPLM) be exceeded.

Mass in Running Order - (MRO)

Mass of the caravan equipped to the

manufacturer's standard specification plus the following:

a) **LPG**

The mass of the recommended gas storage tank(s) when filled to 100% of the permissible maximum capacity. A mass of 10kg per cylinder is assumed and the number of cylinders is equal to the number of connections at the regulator.

b) **Fluids**

The mass of the liquids normally remaining in the systems:

1. Central heating system - full;
2. Freshwater - any fixed water storage tank(s) - empty;
3. Toilet system flushing tank - empty;
4. Toilet system holding tank - empty;
5. Essential fluids for the use of any other items of standard equipment - full.

c) **Electricity supply**

4kg for the low voltage connection cable.

NOTE: No payload allowance is included in the MRO for a full water heater or fresh water tank(s). It is recommended that you tow with the water heater empty.

Warning

The mass of the caravan in running order (MRO) contains provision for the masses of liquids, gas etc. (see mass in running order in user handbook). Part of this provision can also be utilised as additional payload if for example you wish to travel with water tanks empty (if fitted) or with no gas cylinder.

User payload

The user payload allows for items common to all occupants, such as food, cutlery, pots, pans, clothing, footwear, bedding, sports equipment etc.

Towing code

The user payload shall not be less than:

$10L + 10N + 50(\text{kg})$ Where:

L is the overall length of the caravan in metres excluding draw gear as given in ISO 612.

N is the sum of all standard and optional berths.

The mass of the auxiliary battery is not included in the MRO and therefore forms part of the User Payload.

Typical example of weights (Kg)

Kettle	0.5	Aquaroll (Empty)	5
Bed linen	6	Waste bin	1
Crockery	5	Toilet fluid etc.	2.5
Saucepans	3	Cutlery	2
Wastemaster	6	Battery	25

Optional equipment

Items made available by the manufacturer over and above the

standard specification of the caravan.

The manufacturer shall specify the mass of each factory fitted item of optional equipment available including the mass of any fluids required for their safe and proper use.

Alternatively the manufacturer can specify a maximum optional payload available. The user can then choose any options up to this limit.

The mass of optional equipment only includes equipment that is fitted in the factory by the caravan manufacturer. It does not include the mass of any equipment that is fitted to the caravan by the dealership or any other party. The weight of any equipment fitted after the caravan has left the manufacturer forms part of the User Payload.

In either case this mass shall be added to the user payload.

Nose weight

The part of the weight of the caravan supported by the rear of the towing vehicle.

When measuring the nose weight, it is important that the caravan is loaded and level. Do not place extra items indiscriminately into the caravan after this adjustment has been made.

The caravan is intended to be towed slightly nose heavy. The nose weight can be adjusted by distribution of the load within the caravan. You must not exceed the maximum nose weight rating of the hitch head, which is usually a maximum of 100kg (please refer to the detailed vehicle specifications), or that of the towing vehicle as stated in the towing vehicle's manufacturer's handbook. The caravan's nose weight should be as high as practical; taking into account the towing vehicle and caravan nose weight limits.

Towing vehicle terms

Kerb weight:

The weight of the towing vehicle as defined by the vehicle manufacturer.

The Caravan and Towing Vehicle Weight Ratio

This can be determined by calculation and is equal to:

$$\frac{\text{actual laden mass of caravan}}{\text{kerb weight of towing vehicle} \times 100\%}$$

Warning

The law requires that caravans & their towing vehicles & the loads they carry must be in such a condition that no danger or nuisance is caused. (Regulation 100 of the Road and Vehicles (Construction and Use) Regulations 1986).

Measurement of nose weight:

Nose weight may be measured using a proprietary brand of nose weight indicator. Such equipment is obtainable from your caravan dealer.

All proprietary measuring devices will have tolerances and therefore give differing readings.

Another simple method is to use bathroom scales under the coupling head with a piece of wood between the coupling head and the scales, of such length that the caravan floor is horizontal with the jockey wheel raised.

Nose weight can be adjusted simply by distribution of weights in the caravan.

(See Loading)

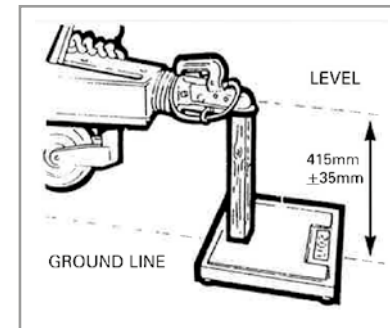
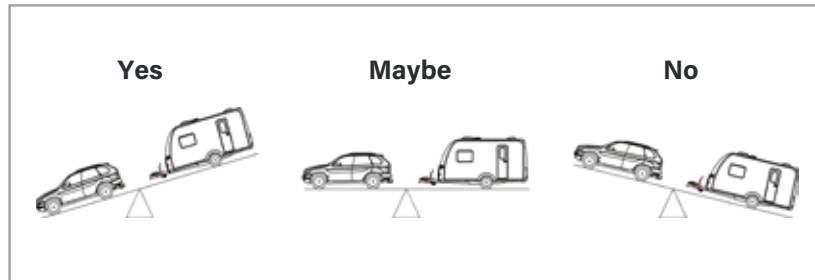

Towing code

Insurance

Compulsory third party insurance cover is required by the Road Traffic Act for a caravan and this is normally provided by the towing car insurance policy, but it is essential that you ensure your car policy is not invalidated by towing.

Do not forget to take out separate insurance cover on the caravan and contents.

Loading and distribution of weight

Under no circumstances should the MTPLM of this caravan be exceeded.

When the towing vehicle and caravan are fully laden and "ready to go" the towing vehicle should be level as reasonable practice. If the nose of the caravan is high at the start of your journey you may experience snaking and on rough and uneven ground the rear of the caravan could catch the road.

Caravans should be loaded so that the nose weight of the caravan is in accordance with the tow vehicle manufacturer's recommendation. Also under no circumstances should it exceed the maximum hitch weight shown in the specification for the caravan.

Heavy items should be stowed as close to the axle as possible and lightweight items, such as bedding, should be loaded at the rear. Try to stow bulky tinned supplies in the lower kitchen cupboards or even in the bottom of the bed boxes

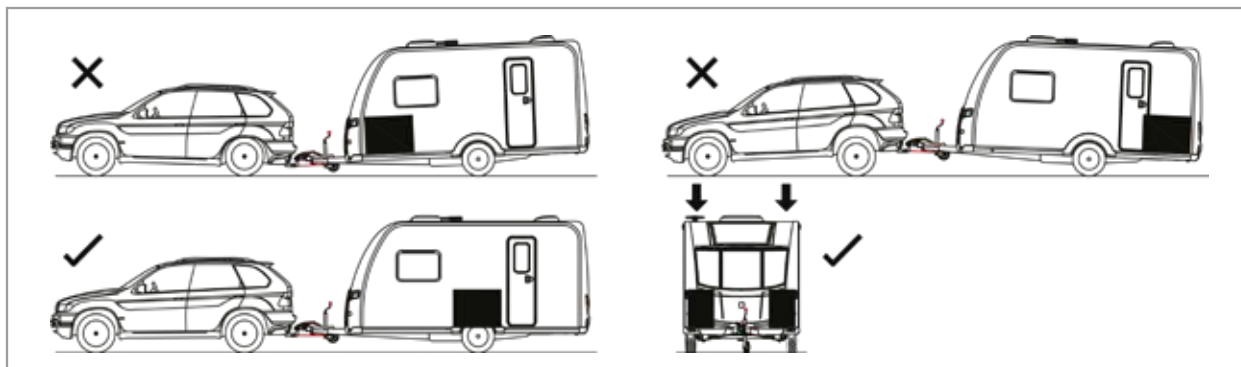

until you arrive at your final destination. Please note that the roller catches and spring loaded doors are only to keep the door closed and not to stop items falling out of lockers and on to work surfaces. Only light items should be stowed high up in the roof lockers. Ensure that all items are secure and will not move around while on tow.

Towing vehicle's rear suspension

It is important that the towing vehicle's rear suspension is not deflected excessively by the nose weight on the tow ball. If it is excessive the steering and stability will be affected.

The greater the towing vehicle's tail overhang (the distance between the rear axle and the tow ball) the greater the effect the nose weight will have on the towing vehicle's rear suspension.

After trying out the caravan it may be found that stiffening of the vehicle's rear suspension is necessary - note that this may give the towing vehicle a firmer ride

when not towing.

There are a number of suspension aids available and advice should be sought on which to use and how to fit.

It is important to ensure that the caravan is towed either level or slightly nose down. This is particularly important on twin axle models.

Stability

The most common causes of poor stability include:

- a) Worn shock absorbers or loose suspension components on the towing vehicle.
- b) Towing vehicle springs too soft.
- c) Insufficient nose weight.
- d) Nose of caravan is towing too high.
- e) Incorrect loading.
- f) Incorrect tyre pressures on car or caravan.

Tyres and Pressures

The tyres fitted to your caravan will operate with complete safety at the UK maximum speed limit of 60 mph, but the tyres are rated to 130 km/hr. The tyres on your caravan must be operated at the pressures indicated on the caravan's specification sheet. Remember that the towing vehicle tyres should be inflated to the 'heavy loaded' pressure given in the technical data section in this manual.

NOTE: Pressures should only be checked when the tyres are cold, not after a journey or if the vehicle has been standing in the sun.

Tyre Tread

This caravan is subject to the same criteria applied to car tyres, namely, the minimum tread should be 1.6 mm around the total circumference and across the entire width of the tyre, as per standard motor vehicle requirements.

Brakes/Breakaway cable

A breakaway cable is fitted so that in the

Preparing for the road

case of the caravan becoming detached from the car it immediately applies the brakes. Always ensure the breakaway cable is secured to the towing vehicle. Refer to breakaway cable section.

Snaking

This is a term used to denote an unstable car and caravan combination where the caravan 'weaves' from side to side often causing a similar swaying movement in the car itself.

Causes:

- I. Unsuitable or unbalanced outfit.
- II. Incorrect loading or weight distribution.
- III. Excessive speed especially downhill.
- IV. Side winds.
- V. Overtaking.
- VI. Being overtaken by a large fast moving vehicle.
- VII. Erratic driving.

VIII. Insufficient tyre pressure.

IX. Incorrect vehicle tow ball height

X. Worn stabiliser pads or tow ball.

Cures:

Cases of persistent snaking can be alleviated or even completely cured by various proprietary devices, about which your dealer will advise you.

Warning

Never enter the caravan without first lowering the four corner steadies with the brace provided. Corner steadies should not be used as a jacking device, or to take the weight of the caravan.

Pre-tow checklist and hitch-up

Loose articles must be stowed securely. Do not stow tins, bottles or heavy items in overhead lockers prior to towing.

- Ensure all lockers and cupboard doors

are closed and secured.

- All bunks are secure.
- All rooflights are closed and secured.
- Tables are stored in their transit positions.
- Fridge is on 12V operation and door travel catch is set.

Warning

Turn off all gas appliances except those heating appliances designed to function while the vehicle is in motion.

Turn off all gas appliances and the gas supply bottle while re-fueling the tow vehicle.

Warning

Ensure gas cylinders and appliances are correctly positioned, secured and turned off.

- All windows are fully closed and latched. Never tow with windows on night setting.
- Leave all curtains and blinds open to

- Battery is secure and mains connecting cable is disconnected and stowed.
- Check gas locker, battery locker, wet locker and cassette toilet doors are secure.
- Check wheel bolts, tyre pressures and tyre conditions.
- Lock the entrance door.

Towing Vehicles

Your new caravan is designed to be towed by a normal motor car.

If you intend to tow with a pick up type vehicle, passenger derived van or a 4x4 type vehicle, additional care should be exercised because of the potential for a harder rear suspension on such vehicles which may impose excessive loads on the caravans. You may also have to adjust your driving style over rough terrain and particular attention should be given to the height of the tow ball in relation to the caravan coupling.

- Ref: UNECE R55

The height of the tow ball on the towing

vehicle, when laden, is also critical. To comply with UNECE regulation R55, the towing vehicle tow ball should be between 350mm and 420mm from the ground.

Your new caravan should not be towed by a commercial vehicle with a gross weight in excess of 3500kgs.

When selecting a towing vehicle, it is recommended that you check the NCC

Warning

Many modern cars are equipped with 'stop/start' technology. Once the engine has stopped, the fridge may not be supplied power and will turn off. The fridge will have to be manually switched back on to 12V operation. It is therefore, best to turn off the 'Stop/Start' feature if possible.

website "Towcheck" www.towcheck.co.uk to ensure your car and touring caravan combination is safe and legal.

Smart Alternators

Coachman will assume that the vehicle tow bar and trailer electric connection have been installed with the specific requirements needed for the connection of a caravan. The caravan needs a supply suitable for the AL-KO ATC unit and the fridge where a generic box trailer won't. Tow bars that have been retro fitted will generally have a relay fitted which should provide the power needed by the caravan equipment.

If problems are being experienced with the electrical supply to the fridge, then an Auto Electrician should verify the power output at the connection outlet of the tow vehicle.

Battery hybrid vehicles and vehicles fitted with a smart alternator may not recognise the electrical load being applied by the caravan so the equipment may not work. In this instance, advice should be sought from the vehicle manufacturer, an Auto Electrician or a tow bar specialist.

Products such as a DC to DC voltage

Preparing for the road

booster can be fitted, if the power supplied by the tow vehicle is inadequate to supply auxiliary components while towing.

Stabilisers and traction control

All Coachman caravans come fitted with a stabiliser. It can make a good towing vehicle/caravan combination safer to handle. A stabiliser should never be used to try to improve a combination which has poor stability, since instability will reappear at a higher speed.

Warning

Under no circumstances should holes be drilled into the chassis members e.g. for fitting additional equipment.

Coachman caravans are also equipped for the fitment of the AL-KO Trailer Control System (ATC) and some models have it fitted as standard.

The AL-KO ATC is the emergency braking system for caravans and

works in a similar way to Electronic Stability Programme systems for cars. The electronic system monitors the lateral movement of a caravan during travel. When difficult driving conditions are experienced, such as evasive manoeuvring, high side winds and turbulence encountered while overtaking HGVs, AL-KO ATC takes control to regain stability and prevent dangerous snaking accidents.

ATC operating instructions

After coupling the caravan correctly to the towing vehicle, connect the 13 pin plug to the tow bar.

Upon connection, ATC will carry out an initial self-test and the LED light on the front fairing will light up RED. During the self-test, the sound of the push rod moving inside ATC can be heard. When the self-test is complete, the LED will turn GREEN or flashing GREEN to signal that ATC is active.

⚠ Warning

A 20 amp fuse is required on the actual towing vehicle on the constant 12V supply. Please check with your vehicle dealer/towbar installer. If only a single fuse is fitted at the tow bar a minimum fuse rating of 25 amps must be used.

⚠ Warning

When providing power from an independent supply e.g. a portable power pack, it is necessary that a battery rated at least 12V 55 Ah is used to supply the auxiliary feed. It is also important that the power supply is fused at 20 amps.

⚠ Warning

Please be aware your ATC is 'live' all of the time your 13 pin connection is made. If the car and caravan are stood for a long period of time (e.g. ferry crossing) the ATC will continue to draw power from your battery.

If the LED does not change to GREEN, then ATC is not functioning correctly. For details of what to do in this case, see the provided table on page 21.

Always re-check the ATC LED is green after any interval during a journey, such as a service station break.

ATC LED light on the fairing

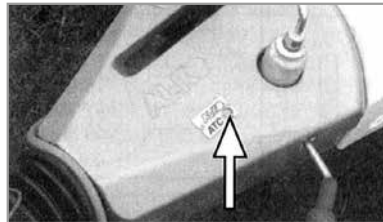

Troubleshooting

Should you experience a fault with ATC the LED light on the fairing will change colour. Therefore, refer to the table on page 21 and follow the instructions.

If no illumination of the LED is evident, refer to system requirements and check

tow bar wiring for permanent supply. In the unlikely event that you receive a red flashing LED light and disconnecting and re-connecting the power does not alleviate the problem, check the push rod position as detailed. Locate ATC on the axle and check the position of the push rod. (See photograph).

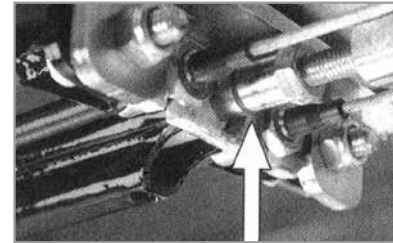

If no red line is visible, ATC is not active and can be driven. However, we recommend that you contact AL-KO at the earliest convenience.

If the red line is visible on the push rod, as show above, the caravan should not be moved. Contact AL-KO or a specialist workshop.

Preparing for the road

Display colour	ATC Condition	Diagnosis	What to do	Outcome	Status
Green	ATC active	Everything OK			
Green flashing	ATC active	Self test incomplete	Drive forward to detect movement to complete self test and re check LED	Green (Constant)	Ready for journey
Red	ATC inactive	Possible to continue journey.	Remove 13 pin plug and wait 5 seconds. Reconnect plug	Green Red	Ready for journey. ATC faulty but can be driven. Consult AL-KO. See AL-KO handbook for details
Red flashing	ATC has detected a fault	Do not continue with ATC connected	Remove 13 pin plug and wait 5 seconds. Reconnect the plug.	Green Red (flashing)	Ready for journey. ATC faulty and cannot be driven. Remove push-rod as shown in the AL-KO handbook. Consult AL-KO. See AL-KO handbook for details.
LED not working	ATC has no power. LED faulty	Check push rod position as detailed in the AL-KO handbook before continuing your journey.	Remove 13 pin plug and wait 5 seconds. Reconnect the plug. Check for constant live - refer to system requirements as detailed in the AL-KO handbook.	Green. LED not working.	Ready for journey. If power OK, check push rod position. Red line visible - possible to continue journey but consult AL-KO. See AL-KO handbook for details.

Prior to commencing any journey, ensure that the caravan lighting is fully operational and check the vehicle is loaded appropriately, the nose weight and tyre pressure are correct and confirm that the caravan is couple to the vehicle tow bar correctly.

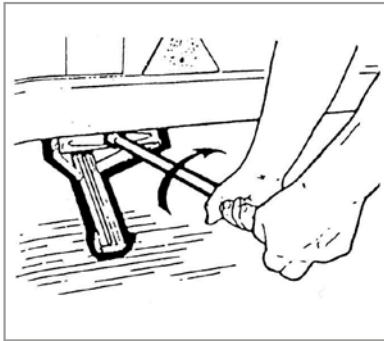

Hitching up

Wind up the corner steadies to the fully retracted position.

Wind up the jockey wheel to raise the hitch to the above height of the towing vehicle ball. Remove ball cover.

(It is an advantage to have a person standing by the caravan to direct the driver of the towing vehicle to place the vehicle in the correct position.)

Reverse the towing vehicle so that the

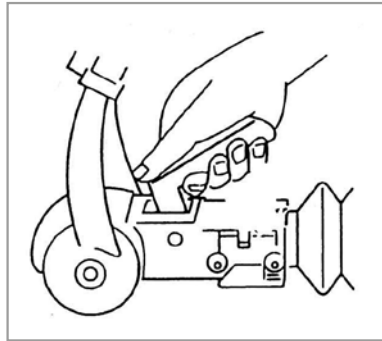

towing ball is just under the caravan hitch.

Operating Instructions - AKS 3004

The AKS 3004 stabiliser fitted to your caravan has 4 special friction pads, which suppress both snaking and pitching and it is essential that the tow ball is kept completely clean as contaminated pads will reduce its effectiveness.

The maximum vertical static load for this coupling is 100kg and must not be

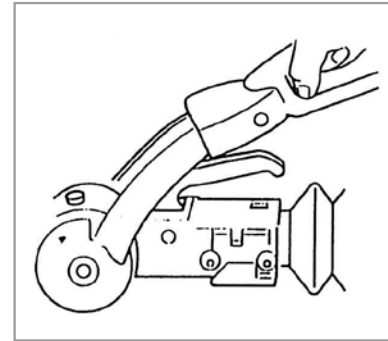

exceeded. However, the vertical static load on the towing vehicle may be less than this (check with towing vehicle manufacturer). Whichever is the least must not be exceeded.

Preparing for the road

To hitch up with the AKS 3004 follow the following procedure:

⚠ Warning

The tow ball should be free of grease and rust, undamaged and not excessively worn.

- Using the coupling handle (which should be in the upright position), put the AKS on to the towball. Push the black handle down and check the green indicator button is showing. **(Fig. 1)**

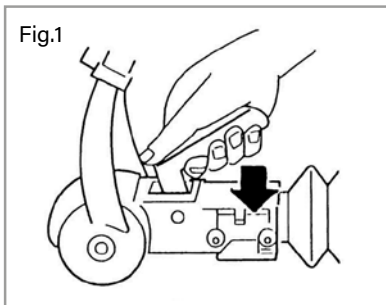

- Press the red stabilising lever down. The AKS is now ready for the road. **(Fig. 2)**

Safety Indicators

- If the green indicator is visible then you know you have correctly coupled your AKS to your towing vehicle. **(Fig. 3)**

Wear Indicator

For coupling mechanism and front/rear friction pads. **(Fig. 4)**

- Wear of the coupling ball and mechanism can be easily monitored. If the green section is visible (when

coupled to your towball) then the front/rear friction pads, coupling ball and mechanism are in order.

- If the red lower section obscures the green section then you need to check these parts immediately.

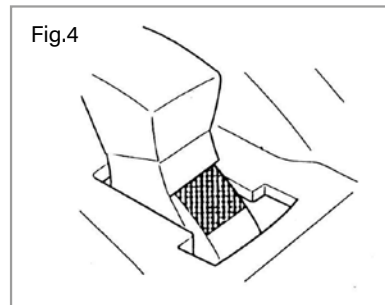
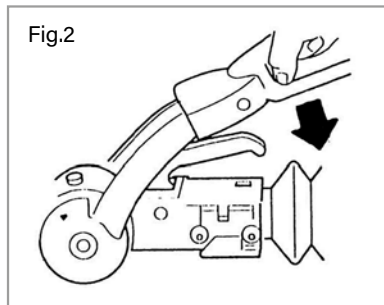
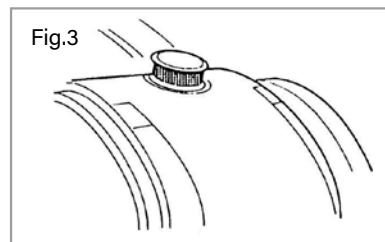

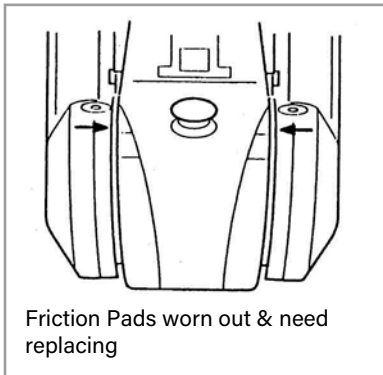
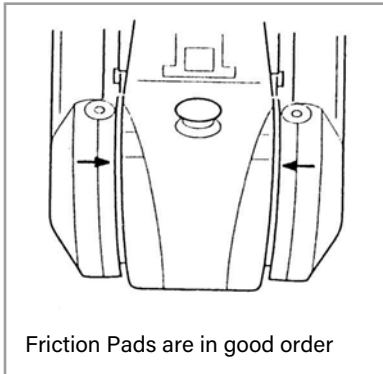

Friction Pads Replacement

- Unscrew the 2 screws which are under the red rubber soft dock by using the special tool. **(Fig. 5)**
- Remove screw from back plate. **(Fig. 6)**
- Remove friction pads. **(Fig. 7)**

Loading capacity

The AKS 3004 can tow vehicles up to gross weight of 3000kg and a maximum nose weight of 100kg.

Uncoupling

Lower the jockey wheel to the ground. Disconnect the breakaway cable and plugs.

Release stabilising lever and lift the coupling handle whilst winding. Lift the coupling head clear of the towball.

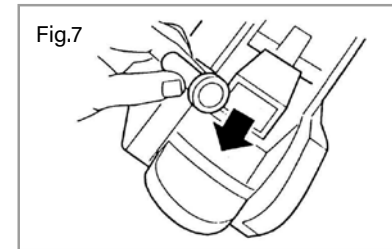
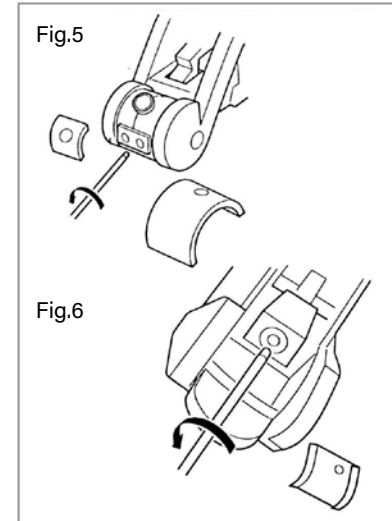

Preparing for the road

Electrical Connections and Road Lighting

Plug in the 13 pin electrical connections and check that all road lights work.

In accordance with EN150 11446 your caravan is fitted with a 13 pin Jaegar plug for electrical connections and road lighting. If your car is fitted with the old type 12N and 12S sockets we would strongly recommend that you do not use adapters but have it rewired and a 13 pin Jaegar socket fitted. (Ensuring the car socket is wired in accordance with the drawing below.)

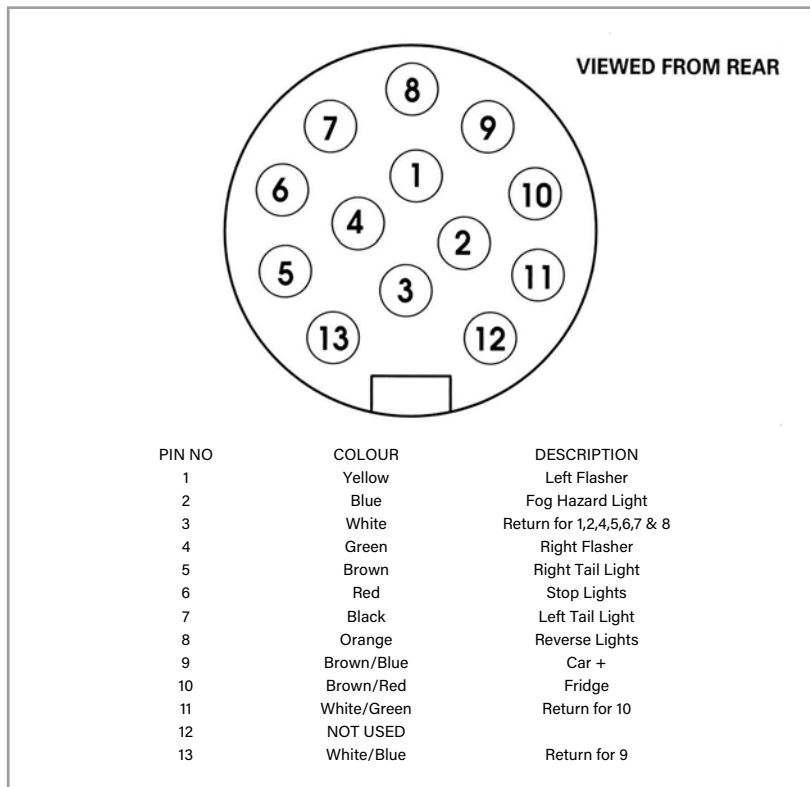

Breakaway cable

UK law requires that all trailers with brakes built on or after 1st October 1982 (e.g. caravans, horse boxes, flat bed car trailers etc.) are fitted with a safety device to provide protection in the unlikely event of the separation of the main coupling while in motion. A device referred to as a "breakaway cable" fulfills this requirement and when fitted to a trailer its use is mandatory. For further information please refer to:

www.thencc.org.uk/media/hw0f5ew1/ncc-towing-guide.pdf

Purpose - To apply a trailer's brakes if it becomes separated from its towing vehicle. Having done this, the cable assembly is designed to part, allowing the trailer to come to a halt away from the towing vehicle.

Construction - Usually a thin steel cable, possibly plastic coated, and fitted with a means of attachment for connection to the towing vehicle.

Operation - In the event of the main coupling of the trailer separating from the towing vehicle, the cable should be able to pull tight, without any hindrance, engaging the trailer's brakes.

NOTE: The breakaway cable should never become taut during normal use.

Correct procedure for use:

- Regularly check the cable and clip for damage. If in doubt, contact your dealer or service agent.
- Make sure the cable runs as straight as possible and goes through a cable guide underneath the trailer coupling.
- Determine whether or not the towbar has a designated attachment point (i.e. a part specifically designated by its manufacturer for a breakaway cable).

Where a designated attachment point is provided on the towbar:

Either: a) Pass the cable through the attachment point and clip it back on itself (Fig. 1)

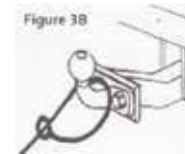
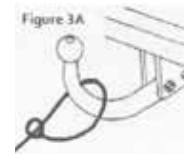
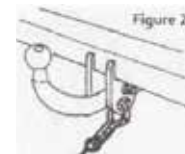
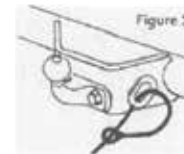

Or: b) Attach the clip directly to the designated point (Fig.2). This alternative must be specifically permitted by the trailer manufacturer since the clip may not be sufficiently strong for use in this way.

Where NO designated attachment point is provided on the towbar:

Fixed ball: Loop the cable around the neck of the towball. If you fit the cable like this, use a single loop only. See figs. 3A and 3B.

Preparing for the road

Detachable ball: You must seek guidance on procedure from the towbar manufacturer or supplier.

When the breakaway cable is attached, check to ensure:

- a) That the cable cannot snag in use on the trailer coupling head, jockey wheel, or any accessory e.g. a stabiliser, bumper shield, cycle carrier, etc.
- b) That there is sufficient slack in the cable to allow the towing vehicle and trailer to articulate fully without the cable ever becoming taut and applying the brakes.

NOTE: For peace of mind you might wish to check the state of the cable by positioning the trailer and towing vehicle at extreme angles before setting off.

- c) That it is not so slack that it can drag on the ground. If left loose, the cable may scrape along the ground and be weakened so that it subsequently fails to do its job. The cable may also be

caught on an obstacle when in motion thus engaging the trailer brakes prematurely.

Having followed this advice, should you feel that a satisfactory coupling arrangement cannot be achieved, consult your dealer.

Mirrors

There is a legal requirement for you to have mirrors that allow you to see clearly an area that is 4 metres wide from the side of your caravan at a distance 20 metres behind the driver. A caravan is significantly wider than a car even a large 4x4 and you simply can't comply with the law unless you fit towing mirrors. The driver of the towing vehicle must have an adequate view of the rear.

If there is no rear view through the caravan it is essential that additional exterior towing mirrors are fitted.

Any rear view mirror fitted shall be 'e' marked and cover the field of view as stipulated by type approved

requirements (Regulation 33 of the Road Vehicles Constructions and Use Regulation 1986).

Warning

Any rear view mirror must not project more than 250mm outside:

- a) the width of the caravan when being towed.
- b) the width of the towing vehicle when driven solo

Coupling up a caravan check list

1. Is the hitch fully down over the tow ball?
2. Is the hitch head lever fully closed (down)?
3. Are the visual indicators showing green?
4. Is the breakaway cable correctly attached, passing through the cable guide, loose but not dragging, and will not snag on full lock?
5. Is the stabiliser correctly attached, with the handle closed and indicators green?
6. Is the jockey wheel fully retracted and stowed away securely?
7. Are the electrics correctly attached and free from dragging or snagging on full lock?
8. Have the lights and road indicators been checked and are they working?
9. Once "Hitched Up", are the corner steadies fully retracted, and the caravan handbrake OFF?
10. Has the caravan step been stowed away?
11. Are the caravan door, windows, lockers and roof lights closed and secured?
12. Is the rear number plate correct and clearly visible?
13. Is the gas system turned off for towing?
14. If fitted check ATC system. (See page 22)
15. Is the caravan loaded correctly and all items secure?
16. Is the sink empty of all items including the bowl?

Speed limits

Normal road towing: 50mph (80 kph) - normal speed restrictions apply

Motorways (including dual carriageways): 60mph (96 kph) - normal speed restrictions apply

Pulling off

Let the clutch out smoothly.

Allow more engine speed to produce the power to move the additional weight of the caravan.

Avoid wear and tear on clutch and transmission by taking extra care.

Change gears smoothly. Try not to jerk the clutch.

Caravan handling

Allow for caravan being wider than car.

Do not bump kerb with caravan wheels. When passing other vehicles allow more than normal clearance for driving solo. Allow longer to get up speed to pass.

Allow for the vehicle being twice its normal length.

Do not suddenly swing out.

Carry out all manoeuvres as smoothly as possible.

Use nearside wing mirror to check

Towing and driving

caravan has cleared when overtaking.

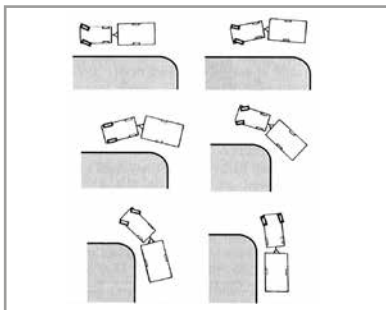

Midway through the manoeuvre, when the caravan is correctly angled, slow to a crawl and gradually apply opposite lock. Make the car follow the caravan round then finally straighten up.

Proficiency at reversing can only be achieved with practice.

Warning

Care must be taken to prevent fouling when traversing ramps or other ground obstacles.

Warning

Caravans may not be towed in the outside lane of a three or four lane motorway. (Ref. 12(2) of the Motorway Traffic (England and Wales) Regulations 1982)

Reversing

It is advisable to have a second person available when reversing the caravan. Start practising by choosing a left-hand bend for ease. Reverse slowly, turning the wheel, initially the opposite way to the direction you want the caravan to go.

Now the front of the caravan is nudged out and moving the rear in the intended direction. Take care not to hit the caravan with the car!

Motorway driving

1. Reduce speed:
 - i) In high or cross winds.
 - ii) Downhill.
 - iii) In poor visibility.
 - iv) Poor road conditions.
2. High sided vehicles cause air buffeting so extra care must be taken when passing or being passed. As much space as possible should be given.

Changing a wheel

1. Unhitch the caravan and ensure handbrake is applied.
2. Lower the front of your caravan by retracting the jockey wheel as much as possible.
3. Lower the corner steadies, as a safety measure, to stabilise the caravan. Do not use to jack up caravan.
4. Your spare wheel is located in the AL-KO Group spare wheel carrier

situated just behind the axle.

5. To remove the spare wheel from the carrier, locate hand wheel situated on the centre of the spare wheel carrier retaining plate on the nearside of the chassis and remove the split ring in the hole at the end of the bolt. Now loosen and remove the hand wheel.
6. Now slide the carrier out of the locating holes on the chassis and rest the nearside on the floor.
7. Reach into the centre of the spare wheel and remove the clamping sleeve and the retaining wheel nut. Remove spare wheel from carrier.
8. Use your wheel brace to slacken off the wheel bolts on the wheel to be changed.
9. If your caravan has a jack receiver fitted, jack up the caravan in line with the instructions. If not, position a suitable jack under the axle at the appropriate jacking point (rear axle on twin axle models) (on soft ground use something to act as a spreader plate).

10. Jack up caravan until the wheel to be removed is just off the ground.
11. Remove the wheel bolts and remove the wheel.
12. Fit spare wheel and reverse the above procedure placing the punctured wheel in the wheel carrier.

Warning

Ensure the wheel is of the same construction and size as the one that has been removed.

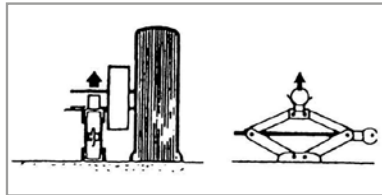

13. Tighten all bolts equally in order shown in the diagram.

Warning

If you are unsure about your ability to perform the safe elevation of your vehicle, or the process of wheel removal and refitting, then please enlist the help of a professional service.

Towing and driving/Safety and security

Torque settings are:

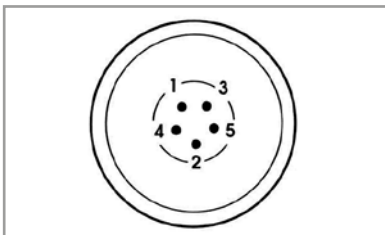

⚠ Warning

1. After the first 30 miles check all road wheel bolts and tighten, if required, to correct torque setting.
2. Check wheel bolt torque before each major journey.
3. Never use grease of any kind on wheel bolts.

Steel wheels	88Nm	(65 lbs/ft).
Alloy wheels	130Nm	(96 lbs/ft).

Wheel bolt tightening sequence

Before fitting a new wheel, examine it for distortion or other damage. Ensure that

all mating surfaces are clean and dry, including bolt seats.

Always use the correct bolts to secure the wheel. There are unique bolts for alloy wheels and under no circumstances should any other bolts be used with alloy. Alloy wheel bolts have a tapered neck. These bolts can be used on both alloy and steel wheels.

Please note with Alloy Wheels you should first tighten all bolts to 85Nm (63lbs/ft) then go around again in the sequence shown and increase the torque from 85Nm (63lbs/ft) to 130Nm (96lbs/ft). The correct conical and tapered wheel bolts (stamped 10.9) must be used.

Safety and Security

IMPORTANT: Your attention is drawn to the notice affixed in the caravan advising on fire prevention, ventilation and what to do in case of fire.

Children

Do not leave children alone in the caravan. Keep potentially dangerous items, e.g. matches, drugs etc, out of reach, as at home.

Fire extinguisher

It is recommended that you provide one dry powder fire extinguisher, of an approved type or complying with EN 3-7, of at least 1kg capacity by main exit door, and a fire blanket next to the cooker.

Familiarise yourself with the instructions on the fire extinguisher and the local fire precaution arrangements.

A fat pan must not have an extinguisher aimed at it, but must be smothered by a fire blanket.

In case of fire

1. Get everyone out of the caravan as quickly as possible using whichever exit is quickest including windows. Do not stop to collect any personal items.
2. Raise the alarm. Call the fire brigade.

3. Turn off gas container valve if safe to do so.

Ventilation and condensation

All caravans comply with EN 721. The ventilation points on your caravan are fixed points of ventilation, which are required by the European Standards. Low level ventilation is located at various points. High level ventilation is through the roof lights. It is advised that fixed ventilation points are checked and cleaned (if necessary) on a regular basis.

Condensation will occur where warm moist air is put into the atmosphere in areas such as in bathrooms (during showering) and in kitchen areas (during cooking). In the enclosed space of a caravan the moist air from the kitchen or bathroom area will inevitably transfer to the rest of the vehicle which in turn condenses on cold surfaces leading to visible water droplets.

Condensation will also form in cold areas where air movement and ventilation is restricted (e.g. cupboards, wardrobes,

under beds, etc.). It is important to provide ventilation and air flow so that the warm moist air can escape or be externally cooled and use the heating reasonably by not making the caravan/motorhome too warm such that people perspire as this will only serve to generate more moist air and therefore more condensation.

However, in particularly cold periods where the external ambient temperatures are low, condensation may still form on external walls as the insulation levels may well not be thermally able to cope with the difference between the internal and external temperatures. Provide ventilation so that moist air can escape.

- Good ventilation of the vehicle when cooking or when drying clothes, footwear or pets is essential. Observe when windows begin to show signs of misting and increase ventilation by opening slightly by 1cm or opening a roof vent as these will help, but keep the habitation door closed as much as possible to retain heat.

- If drying damp clothes or towels open a window to ventilate the area and allow the moist air to escape.

Warning

Under no circumstances must these vents be blocked or obstructed, even partially.

NOTE: It is recommended to let in some additional ventilation whilst sleeping. This will help to avoid condensation build-up. Windows can be adjusted onto the night latch setting to help minimise condensation.

Warning

Petrol/Diesel Fumes

The fitting of a tail pipe to your exhaust will reduce the possibility of fumes entering your caravan through the front fixed ventilation points.

Arrival at site

⚠ Warning

Never use portable cooking or heating equipment, other than electrical heaters that are not of the radiant type, as it is a fire and asphyxiation hazard.

Check site regulations for any local restrictions

Selecting a pitch

Carefully select where you wish to place your caravan. The site should be as level as possible, preferably not under or near trees, well drained and away from possible boggy areas. Consider how you will move the caravan when it is time to leave the site. On sloping ground it is better to pitch facing downhill, especially during wet weather. It should be noted that some items of caravan equipment are only designed for use up to a 3 degree angle and if this angle is exceeded the components may fail.

It is good practice to chock the wheels of the caravan when parked on a slope even though the caravan brakes are applied.

⚠ Warning

Always disconnect the 13 pin plug between the towing vehicle and the caravan before connecting an LV (230V) supply to the caravan and before charging the caravan battery by any other means.

Unhitching

Apply the caravan handbrake.

Disconnect the breakaway cable.

Disconnect the 13 pin plug and return it to its holder.

Unclamp and lower the jockey wheel to the ground.

Release the stabilising lever and coupling handle.

Operate the handle to wind down the

jockey wheel until the coupling head is clear of the towing ball.

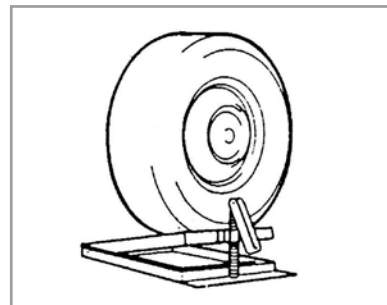

Replace towball cover.

Park your vehicle alongside the caravan as per the site owners instructions.

Lateral levelling

On uneven ground lateral levelling may be accomplished by the use of a leveller jack and a spirit level placed 'across' the caravan floor.

Place the leveller jack, folded flat, in front of the wheel needed to be raised to level the axle.

Tow the caravan onto the leveller jack. Wind up until the spirit level shows that the caravan is laterally level. Apply the caravan handbrake and chock the caravan wheel if necessary. Lower the jockey wheel to ground level.

Proceed with unhitching as described above.

(On upward facing pitches when the hydraulically damped drawbar of the hitch becomes fully extended it will be necessary to compress the drawbar slightly in order to achieve a 'clean' unhitching). With the caravan brake on, reverse the towing vehicle about 1 inch (2.54cm) to release hitch lock tension and using the jockey wheel adjustment unhitch the caravan as previously described.

NOTE: Under no circumstances should the caravan steadies be used as a jack. They are only a means of stabilising the caravan.

FORE and AFT levelling

Warning

Never enter the caravan without first lowering the four corner steadies with the brace provided. Corner steadies should not be used as a jacking device.

Place the spirit level 'fore and aft' and using the jockey wheel adjustment level the caravan horizontally.

Wind down the corner steadies onto load spreaders (blocks of wood a minimum of 6 inches (15.25cm) square taking care not to lift the caravan wheels).

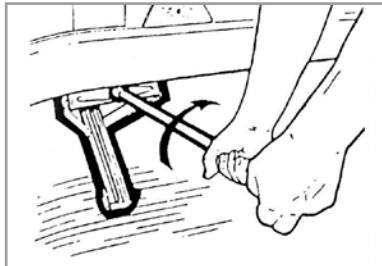

It is important that the caravan is correctly levelled to ensure the correct working of the refrigerator, cooker etc.

Your caravan should not be operated at an angle greater than 3 degrees.

Parking on a reverse - sloping site or steep hill

For successful parking on a reverse slope or steep hill, the operator need only apply the handbrake with one hand while gently but purposely inching the caravan or trailer a small distance backwards with the other.

Warning

If the handbrake is NOT fully applied (i.e. vertical) and is set to some lesser position than the full vertical, then problems will almost certainly arise after the trailer has been uncoupled from the towing unit. On steep hills or sloping sites always chock the caravan wheels.

Arrival at site/Connecting services - Water

E+P Self-Levelling System

Before you use your self-levelling system, please fully read and understand your user manual.

The instructions below are only intended as a basic guide. Detailed operating instructions and trouble shooting can be found in the handbook or E+P hydraulics website.

- 1) Unhitch the caravan from the tow vehicle
- 2) Ensure the nose of the caravan is pointing down
- 3) Switch on the self-levelling system
- 4) The level indicator must show the nose is down (If not, the jockey wheel indicator will show)
- 5) Press the Auto button, The Jacks deployed LED will show
- 6) The maximum slope is 8% or 5°. If the slope is too steep, press the manual operation button to obtain the best level

7) The level indicator lights green when the caravan is level

Connecting services

Connection of services is dealt with under separate headings. In all cases become familiar with manufacturers' instructions.

Before making connections of any description to the caravan, ensure ALL equipment is turned off and that where appropriate switches are moved to the off positions.

Water

Your caravan will be fitted with a Whale IC pump.

Under no circumstances should mains water be connected to the caravan without a pressure reducer.

If using the system after a storage period, carry out checks as outlined in "Setting up the Water System".

Fill fresh water container and place in

suitable position. Place waste water receptacles in position.

Place the submersible pump or filler pipe into the water container, ensuring that it is fully submerged before operating the system.

Waste connection

Your caravan is fitted with a 28mm waste water system. Two waste water outlets are located on the offside of the caravan to the rear of the wheels.

These outlets connect to a standard waste hose, which can then be inserted into suitable waste water containers.

Pressurised water system

Fresh water is supplied to the caravan from either an internal or external pump.

WHALE principles of operation

The Watermaster® IC is a means of control for the Whale Watermaster® High Flow pump, which allows it to operate without the need for pressure switch

adjustment. It offers three key features: eliminates a rapid water pulsation, ensures that the pump turns off at low battery voltages and also in a run-dry situation when the water supply runs out.

This Intelligent Control® is achieved as the pressure switch turns the pump on when the pressure drops to a low level and the microprocessor turning off the pump at programmed current levels. These current levels are set during the simple calibration process. This calibration process may have to be repeated if the pump is replaced, or after the vehicle has been serviced.

Connecting your plug and pump kit

Prior to using your water system for the first time, the system will need to be primed and the Watermaster® IC unit will need to be calibrated by the following simple steps.

To prime the water system

Step one - Place the pump into a full water container. Ensure the pump can

reach the bottom.

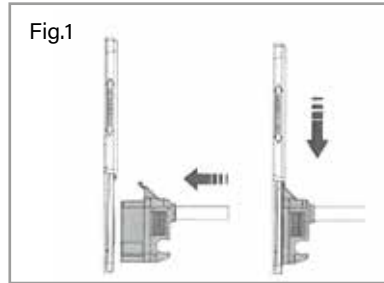

Step two - Insert Easi-Push plug into socket and slide the lid to lock into place see Fig.1 above.

Step three - Adjust dust cover opening in container (please note dust cover should not be secured to water container as air must be allowed to enter container to replace water being pumped out).

Step four - Switch on 12 volt supply at main panel (Isolator switch) - the pump should start to run.

Step five - Open the cold shower mixer (or the outlet furthest from the Watermaster® IC Control Unit in the van).

Step six - After trapped air has been expelled, by following Step five, water will flow from the open outlet.

Step seven - When air has been expelled turn off the shower, the pump should turn off after approximately 10 seconds.

Step eight - Repeat this operation with the hot taps until there is a good flow. This will take longer as your water heater will be filling.

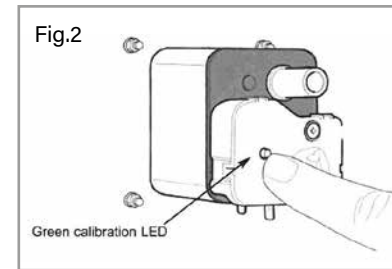

Calibration

To ensure successful installation and optimum performance of the

Connecting services - Water

Watermaster® IC Control unit, you must follow the 5 simple steps below:

Step one - Press and hold the calibration button until the green LED starts to flash after 1-3 seconds (see Fig.2)

Step two - Open the cold shower and the pump should start (there may be a short delay).

Step three - After approximately 30 seconds, turn off the shower.

Step four - After approximately 10 seconds, (the pump should still be running), press and hold the calibration button again until the LED turns green and the pump will stop after approximately 10 seconds.

Step five - The green LED should turn off and blink briefly every 5 seconds. The system is now calibrated.

The Watermaster® is now installed and ready for use. During normal use you will only need to recalibrate if you use a different pump (or your vehicle has been into a service centre). Simply repeat the

steps above to calibrate a new pump.

Please note: When the tap is first opened a small drop in water pressure is normal until the pump starts running.

Please note: In normal operation the pump may run for up to 15 seconds after the tap is closed.

Handy hint: Pump hose can be inserted into groove on plug to keep pump off ground while refilling water container. (Fig. 3). The plug must always be removed before moving the caravan/ motorhome.

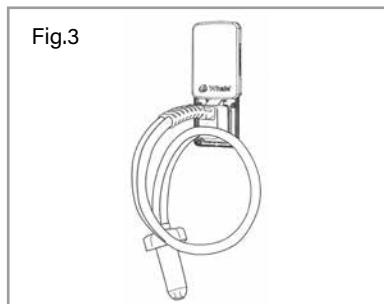

Removing the pump

Step one - Slide up the lid to unlock the plug.

Step two - Pull out plug from socket using hand grip.

Step three - Slide to close.

Pump storage

The plug must always be removed from the external water socket before moving the caravan and stowed in a clean, dry place.

Maintenance

This IC control unit (located on the back of the socket) is designed to be service free and does not contain serviceable parts. Please note that the unit is enclosed to protect the electronics. Opening the wall unit will result in damage, and will invalidate warranty.

Winterisation

If there is any chance of the temperature falling below freezing when the caravan

is not in use, the water system and toilet system must be winterised. All the taps should be opened; the water filter and the caravan system drained using all the drain taps (cold/hot/water heater) situated within the caravan. Additionally shower heads should be removed and the hose left hanging downwards.

If you have a Whale external shower you must drain the filter housing by connecting up the outside shower and allowing the remaining water to drain by the open shower head.

Clean the water system at the start and end of each season.

FAILURE TO CARRY OUT THIS PROCEDURE MAY INVALIDATE YOUR WARRANTY ON ALL WATER SYSTEM ASSOCIATED PARTS.

Mixer taps

The shower, hand basin and kitchen taps are operated by raising or lowering the handle to control the flow and moving from side to side to blend hot

and cold water to achieve the desired temperature.

WHALE on board system (where fitted)

The onboard water system where fitted gives the user ultimate flexibility of water supply to the caravan.

This includes a self-contained 36 litre inboard tank.

The system can be used in five modes.

1. Supply to the caravan from an external water container.
2. Supply to the caravan from a mains water supply. (By use of an Ultraflow Waterline)
3. Fill the inboard tank from an external water container.
4. Fill the inboard tank from a mains water supply. (By use of an Ultraflow Waterline)
5. Supply the caravan from the inboard tank.

Operation of the water tank system

As submersible pump system, see Control Panel Instructions.

NOTE: The external pump will automatically switch off when the tank is full.

NOTE: Occasionally the water level probe inside the tank may lose its calibration, producing false readings of the tank level. The tank can be re-calibrated by following the procedure detailed on page 59.

Tank drain operation

The water tank should be drained when the vehicle is not in use or is in transit.

To drain the tank, locate the ball valve around the base of the tank. Rotate the black lever to drain the tank. Once drained, close the lever.

NOTE: The tank module is connected to the caravan water system and wiring. Please refer to the Ultraflow instructions.

Connecting services - Water

IMPORTANT - Auto change over.

The lower float switch within the tank will automatically switch over to an external water supply when the tank water level drops below the bottom float position.

Maintenance

To clean and sterilise inside the water tank, use diluted sterilising fluid and fully flush tank with water afterwards. Ensure an industry recommended

freshwater tank cleaner is used.

Troubleshooting

The Whale water tank is fitted with a control module. In the unlikely event you are experiencing problems with the system, please refer to the table above.

If the problem persists contact Whale Support on 028 9127 0531

Winterising

Freezing in winter may cause damage

to the Whale tank and module. To avoid this damage, ensure the system is completely drained. Please see storage and winterisation section.

1. Drain the fresh water tank using the drain valve.
2. Turn pump on and open all taps (including drain valve) and allow the pump to purge the water from the system (not suitable for submersible systems).

Problem	Possible Causes	Potential Solution
Pump fails to turn on	Loose wiring connection Pump circuit has no power. Blown fuse. Pressure switch failure. Defective motor.	Remake a sound connection. Replace fuse/reset. Reset pressure switch using manufacturer's instructions. Replace pump.
Float switches fail to operate.	Loose wiring connection. Defective switch.	Remake a sound connection. Contact Whale Support.
Tank leaking from drain plug	Drain stem not engaged past O-ring.	Reseal ensuring the drain system is fully home.

3. Open the taps until water flow stops (suitable for submersible systems).
4. Turn off power isolator switch for water pump.
5. Remember to leave all outlets and taps open.

FAILURE TO CARRY OUT THIS PROCEDURE MAY INVALIDATE YOUR WARRANTY ON ALL WATER SYSTEM ASSOCIATED PARTS.

Travelling

Do not travel with water in the tank. It is strongly recommended that all water is drained from the tank before travelling.

Gas (LPG)

The gas installation of your caravan has been designed to meet the requirement of EN1949 and BS 5482.

EN1949 requires a fixed outlet pressure regardless of the gas type and lays down a harmonised pressure of 30m bars for LPG installations in touring caravans across Europe.

Warning

It should be noted the standard UK domestic butane or propane regulator is not suitable for use on caravans manufactured to EN1949. They are not set on 30 mbar and have a greater outlet pressure tolerance. Likewise the current standard automatic changeover regulator will not be suitable.

Warning

- Do not use appliances which have a different working pressure.
- The gas system should only be modified by competent and qualified persons.
- The gas system and appliances must be inspected/maintained every 12 months (irrespective of usage) by a qualified technician.
- The caravan is designed to accept a maximum of 2 x 7 kg steel butane or 2 x 6 kg propane bottles or 1 x 5 kg.
- Ensure there is no stress at the hose assembly when it is connected to the cylinder.
- If using an external LPG supply the pressure must not be less than 0.3 bar and not greater than 0.5 bar.
- Inspect flexible hoses on a regular basis for deterioration, wear and damage and renew as necessary with an approved type, in any case no later than the expiry date marked on the hose.
- Do not site bottles outside the gas locker compartment as this would necessitate the use of a high pressure hose in excess of 450mm.
- Do not use any additional independent gas appliances inside your caravan.
- When changing cylinders ensure that all appliances are turned off and the service valve is closed.
- Use appliances only for the purpose for which they were designed/installed eg. Do not use cookers as a space heater.

Connecting services - Gas

Your caravan is fitted with a regulator which meets these requirements and thus allows users to move freely between European countries by being able to purchase any LP gas type. Different bottle types are accommodated by using different hose adapters, which connect to the 30 mbar regulator.

Types of gas:

Butane

Butane is supplied in the UK in green or blue bottles.

All these have a male left hand thread except for Camping Gaz, which has a special female right hand, Calor, 7.5 kg and 15 kg bottles have a special clip-on connection.

Continental bottles usually have a male left hand thread similar, but not identical, to UK butane.

Butane is suitable for use at temperatures down to 2°C but will not work below that.

Propane

Propane is supplied in red steel containers or partly red bottles which have a female left hand threaded connector.

Scandinavian countries use the same connector. Germany or Austria supply propane with a male connection.

Propane will work at temperatures as low as - 40°C and is therefore suitable for all winter caravanning.

Connection

Make sure that heating, cooking appliances and gas cylinders are switched off. Ensure the regulator has been connected via the flexible hose supplied by your dealer to the gas bottle.

NOTE: Gas bottle valves should always be in the 'OFF' position when towing.

Hoses

Your caravan will be supplied with a high pressure hose which must be used

between the pressure regulator and your gas bottle (there are different adapters for propane and butane and different types of cylinders).

Ensure that the open end of the gas hose is protected against the entry of dirt or insects if it is to be left disconnected for any extended period.

Gas safety advice

Regularly check flexible gas hose. Finally make sure that each gas appliance is working efficiently to the recommendations of the appliance manufacturers.

Warning

Inspect flexible hoses regularly for deterioration, wear and damage, and renew as necessary with an approved type, in any case not later than the expiry date marked on the hose.



Awning spaces LPG appliance exhaust

There is no danger of pollution of an enclosed awning space from the LPG exhaust from a refrigerator venting into it.

If totally enclosed, water heaters may produce sufficient exhaust to pollute the awning space, from a general comfort, smell and hygiene point of view. In extreme cases there could be a build up of carbon monoxide to a dangerous level.

Caravan owners are advised to allow some fresh air circulation in the awning space when such appliances are in use.

Ventilation

Fresh air circulation should be allowed below the caravan when appliances are in use. At least three sides of the underfloor space should always be kept open and unobstructed especially by snow. Do not make any additional openings in the floor.

Fixed ventilation/gas drop holes are sited under gas appliances in various locations in your tourer.

Gas leak precautions

- a) NO SMOKING, extinguish all naked flames.
- b) If a gas leak is suspected immediately turn off all supply at the cylinder.

Warning

Under no circumstances should fixed ventilation openings or gas appliance flues be obstructed in any manner as this could lead to a build up of dangerous carbon monoxide. Gas drop holes under appliances should also be kept clear at all times.

Grilles and flues should be kept clean and free from dust.

- c) NEVER look for a leak with a naked flame. Always use a soap solution or special leak detecting liquid when testing connections.

- d) DO NOT operate any electrical apparatus, especially light switches. If the leak is not obvious, the caravan should be evacuated and qualified personnel consulted. Turn the supply off at the cylinder.
- e) Avoid naked flames when connecting or changing a cylinder.

Facts about LPG

LPG has been given a smell by the manufacturers in order to identify leaks.

The gas is heavier than air and therefore sinks to the lowest point.

Flue installations

All flue installations should be inspected once a year throughout their length for corrosion. Flues should be replaced if any sign of perforation is found. Ensure that the replacement is of an approved type.

Connecting services - Gas

⚠ Warning

Never allow modification of electrical or LPG systems and appliances except by qualified persons.

Care should be taken that any additional equipment or appliances are installed in accordance with the appliance/equipment manufacturers and Coachman's instructions (e.g. air conditioning, satellite dish, fuel cells etc.)

Aerosols and highly flammable liquids must not be stored in the compartment behind, or adjacent to, any gas appliance.

Some industrial LPG appliances operate at a high pressure and require a 'high pressure' regulator. This often has an adjusting handle on it. NEVER use such a regulator on a caravan.

Gas Equipment Isolation Manifold

This is located in one of the lower cupboards or front beds and the circuits covered by each tap are clearly indicated. If a fault is suspected then isolate the unit involved and consult your dealer.

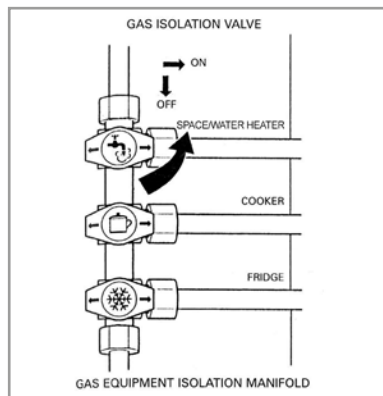

External Quick Release Gas Coupling (BBQ Point)

This is supplied with a nozzle for your appliance which is a simple push-fit into

the coupling on the caravan. To attach, push back the knurled collar on the coupling. This action automatically seals the gas supply and will then allow you to turn on the gas supply.

⚠ Warning

This is to be used as a gas outlet. **Do not use this outlet as a means to input gas into the vehicle.** Do not use a gas barbecue in an enclosed awning space.

⚠ Warning

External LPG supply. To external supply plug-ins should not be less than 0.3 bar and not exceed 0.5 bar.

Changing gas cylinders

If a gas cylinder is to be left disconnected for an extended period, then care must be taken to ensure that dirt and insects cannot enter the open end of the gas supply hose.

Connecting services - Gas

Empty cylinder:

- i. Turn off cylinder valve and all gas appliances.
- ii. Release retaining strap.
- iii. Remove hose connection from cylinder.
- iv. Remove cylinder from gas locker and stand on ground.

Full cylinders:

- i. Remove plastic protector from cylinder.
- ii. Place cylinder in gas locker.
- iii. Connect hose to cylinder (If you are changing the type of cylinder you will have to change this hose or use an adapter - see your dealer). Avoid tension on the rubber gas hose.
- iv. Connect retaining strap.
- v. Turn on cylinder valve and then systematically turn on appliance valves and relight appliances as required.

Electricity mains supply (low voltage)

Warning

Never allow modification of electrical or LPG systems and appliances except by qualified persons.

Care should be taken that any additional equipment or appliances are installed in accordance with the appliance/equipment manufacturers and Coachman's instructions (e.g. air conditioning, satellite dish, fuel cells etc.)

Your caravan's main electrical installation is designed to run on a 230V 50Hz AC supply.

On arrival at caravan site

1. Before connecting the caravan installation to the mains supply, check that:
 - (a) the mains supply is suitable for

your installation and appliances, i.e. whether it is AC or DC and whether it is at the correct voltage and frequency.

- (b) your installation will be properly earthed. Never accept a supply from a socket outlet or plug having only two pins, or from a lighting outlet.
- (c) any residual current device (earth leakage circuit breaker) in the mains supply to the caravan has been tested within the last month.

In case of doubt, consult the site owner or his agent.

2. Make sure that the switch at the site supply point is off and that all electrical equipment in the caravan is switched off.
3. Remove any cover from the electricity inlet provided on the caravan and insert the connector of the supply flexible cable.
4. Remove any cover from the socket

Connecting services - Electricity

outlet provided at the site supply point, and connect the plug at the other end of the supply flexible cable to this. Switch on the main switch at the site supply point.

On leaving caravan site

Reverse the procedure described in Paragraph 3 and 4 above.

NOTE: If you wish to use any 12v appliances, you must turn on at the control panel.

Warning

In case of difficulty consult an approved electrical installation contractor (who may be the local electricity board). It is dangerous to attempt modifications and additions yourself.

Lampholder-plugs (bayonet-cap adaptors) should not in any circumstances be used.

Warning

It is important that the main switch at the site supply point should be switched off, the supply flexible cable disconnected, and any cover replaced on the socket outlet at the site supply point.

It is dangerous to leave the supply socket or supply flexible cable live.

Always disconnect the electrical connector between the towing vehicle and the caravan. Do this before connecting a mains power supply to the caravan, and before charging the caravan leisure battery by any other means.

Periodically, not less than once a year the caravan electrical installation should be inspected and tested and a report on its condition obtained as prescribed in the Regulations for Electrical Installations, published by the Institute of Electrical Engineers.

Connection to a mains voltage supply OVERSEAS requires particular attention.

Care must be taken when connecting supplies abroad since the supplies can be REVERSE POLARITY.

The significance of REVERSE POLARITY is that when equipment is switched off it may not be electrically isolated.

The only certain way of making equipment safe is to unplug it.

A means of checking the polarity of the mains supply when overseas is useful.

There are available several proprietary makes of equipment for the purpose.

If it can be achieved, it is preferable to connect live to live, and neutral to neutral to maintain full electrical protection.

CHECK all caravan equipment is set-up to accept the site supply before actually switching on.

NOTE: It is possible that all of the 230V mains electrical equipment may not be able to be operated simultaneously.

A typical UK caravan site mains hook up point provides a maximum output of 16 amps and on some continental sites the available output may be as low as 5 amps. If your loading exceeds the site supply it may trip the site circuit breaker. Please check the available mains output with your site operator.

The following items need to be added together if used simultaneously.

230V mains equipment typical consumption figures:

Fridge	0.80 amps
Charger	0.80 amps
Water heater	3.7 amps
Blown air heaters (Elec)	8.00 amps
Colour TV	2.50 amps
Microwave	6.00 amps
Air conditioning (Elec)	4.00 amps
Kettle	1.5 KW 6.5 amps
	3.0 KW 13.0 amps

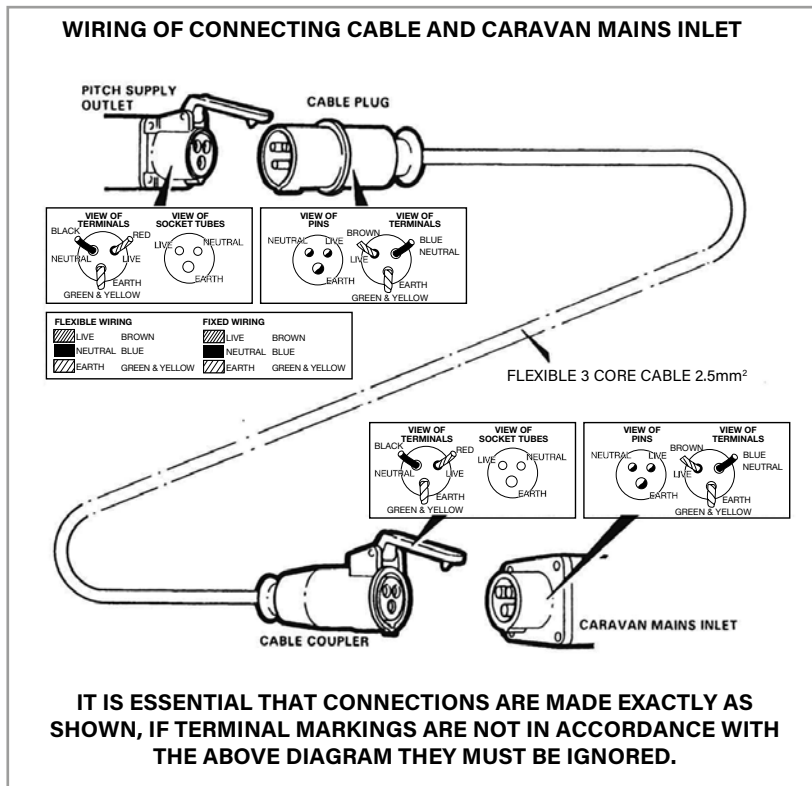

Connecting services - Electricity

12V electrical system (extra low voltage)

Your caravan is fitted with a Power Distribution Unit (PDU). This comprises of the 230 volt RCD and MCB's, Relay housing and Power Supply/Battery charger, this is located under the front off side seat towards the centre of the caravan.

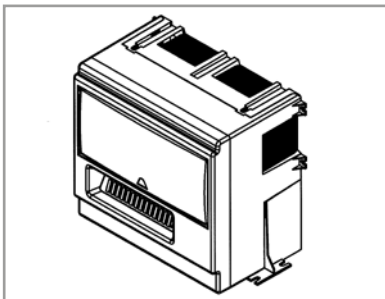

RCD & MCB'S (See Servicing/ Warranty section for 12 volt fuse ratings and locations)

This is for the 230 volt distribution RCD (Residual Current Device) and MCB's

(Miniature Circuit Breakers). The RCD gives protection against electric shock, in the event of an earth fault that would cause earth leakage or earth directly through the human body the RCD will automatically disconnect the whole 230 volt supply. Only after removing the fault will the RCD be able to be switched back to the ON position. This is done by moving the switch upwards against the spring pressure and so restoring the supply.

The MCB's are designed to protect both for the overload of each circuit and also the short circuit. In both events the MCB will automatically switch to the OFF position and when the fault is removed they can be switched upwards against the spring to the ON position. Both the RCD and MCB's will only latch back into position if the fault has been removed. If these devices will not locate back into the ON position consult a qualified electrician.

⚠ Warning

The information provided in the guide relating to fitted equipment is only intended as a quick reference. Comprehensive details of maintenance and fault finding charts where appropriate can be found by referring to the accompanying manufacturer's literature. If any doubts still exist about the operation of the equipment qualified personnel or your caravan dealer should be consulted.

Habitational power and charging

Your caravan is fitted with a single stage power supply, with its primary function to power the 12v electrics in the habitational area, but it can also charge the leisure battery at the voltage rating of 13.8vdc. For most types of battery this is a float charge. This has to be connected

to a 230v supply for this function to work. When disconnected from the 230v supply, the leisure battery will supply the 12v extra low voltage required.

Although this unit will charge the leisure battery it is not a multistage battery charger and therefore will not fully charge the battery. Because of this, we would recommend periodically removing the battery to charge with a specific multistage battery charger.

Power supply specifications

- 13.8v 20A output for DC power and float charge battery charging
- Short circuit protection
- Load dependent fan cooling
- EMC to EN55014-1:2017 and 61000-3-2019
- Safety to 62368-1:2014
- Harmonics to EN61000-1:2016
- High Efficiency

NOTE: A BATTERY MUST BE CONNECTED AT ALL TIMES.

The refrigerator requires that the battery

is connected for the gas igniter to work.

CAUTION!

- As with all types of transformer/ power supply a certain amount of heat is generated, this will vary with the charge rate, therefore adequate space and ventilation must be provided and maintained around the unit to aid cooling.
- Keep all flammable materials and aerosols well away from this appliance and other sources of heat, as this could cause the pressure in the aerosol to rise. Should a seal then fail it is possible an explosion will ensue.
- N.B. Remember any work, replacing parts or repair, must only be carried out when the mains supply has been disconnected, and only by a qualified electrician.

Solar panel

Where caravans are fitted with a Truma solar panel, the panel is rated at 120 watts, meaning in peak conditions

(summer sunshine) it will generate power up to 120 watts.

The panel is bonded to the roof of the van and pre-wired for continuous operation. There are no switches to turn ON or OFF - it is permanently working (during daylight conditions) so long as the panel is connected to the battery via the installed charge controller and is outdoors.

The solar panel will continuously deliver power to charge the leisure battery in the caravan. **Therefore the leisure battery must be connected at all times.**

If the battery is removed you must also remove the in-line fuse for the solar panel. This is located in the fuse holder situated between the regulator and the battery. In order to protect the battery from overcharging and reverse feeding, a charge controller is fitted and can be found located on the front offside bed box.

Connecting services - Electricity

Charge Controller

Please refer to the charge controller instructions. The leisure batteries type will have to be selected on the charge controller. The setting of these switches can be found in the instruction manual.

Purpose and function of the solar panel

The solar panel operates in all daylight conditions and should prevent the battery from discharging during periods of storage (assuming the caravan is outdoors) and it will enable a much higher degree of power self-sufficiency if on a campsite without electric hook-up.

Typically, the panel will generate up to 25Ah per day in peak conditions.

There is no maintenance required with this product, however, it is advisable to clean the panel with water twice per year to ensure best performance.

For any technical questions please contact Truma UK.

Relay housing

Provides the 12 volt distribution throughout the caravan. All the fuses are located at the front of the PDU behind the lift up cover. Ensure fuses being replaced are of the rating indicated on the PDU and never increase the rating of the fuse you replace.

The system is fully compliant with the EMC recommendations within the EU.

When the caravan is plugged into the car the 12 volt's system will be supplied by the car except to the refrigerator.

When the car ignition is switched on and the car is started the system will automatically switch the 12 volt supply in the caravan off, then it will connect the refrigerator 12 volts on and connect the auxiliary battery to charge from the car.

The car alternator, in this mode, will only supply the battery with a small trickle charge.

Please ensure that the voltage supply at the tow vehicles socket is adequate

enough to supply the fridge.

Connecting electricity testing RCD

Periodically it is necessary to test the operation of the RCD. This is achieved by ensuring that it is switched in the ON position with an electricity supply connected and by pressing the test button marked 'T'. The unit should immediately switch to the OFF position. Provided this happens all is correct and the switch should be returned to the ON position, upwards against the spring pressure, to restore the supply back to normal. The RCD also acts as the main switch for the unit and if it is required to switch off all circuits in the caravan this can be achieved by switching the RCD to OFF.

Reverse polarity

When connecting mains supply abroad, the supply can be of reverse polarity. The significance of this is that when equipment is switched OFF it may not be electrically isolated. The only certain

way of making sure equipment is safe is to unplug it.

There are several proprietary makes of equipment to check the polarity of mains supply. This equipment is useful, mostly for mains connection when overseas.

If reverse polarity occurs on site then reverse the live and neutral connections inside the plug on your mains cable. This must be done by a qualified electrician. Ensure that the cable is re-connected to its original configuration on return to the UK.

If it can be achieved, it is preferable to connect live to live, and neutral to neutral to maintain full electrical protection.

Battery box

Located in the battery box below the mains inlet your caravan will be fitted with an aerial and satellite connection if an external source is available.

Warning

Always use battery tray provided.

When using a battery with a vent kit, leave the vent tube in the battery tray. Ventilation is provided through the battery box door when the door is closed at the top and bottom.

Warning

Do not smoke – explosive gases may be present at the battery. Prevent flames and sparks in that area. Switch off all appliances and lamps before connecting or disconnecting the auxiliary battery.

Warning

Batteries should be tested regularly to ensure reliability and safety. Should a fault develop the charger will continue to try to charge the battery leading to possible overheating and failure. If in doubt have it checked by your supplier.

Warning

Any replacement of an auxiliary battery shall be of the same type and specification as that originally fitted or as specified by the manufacturer.

Connecting services - Electricity

Battery Type

It is recommended that a top quality 12V leisure battery of a sealed type is used which is essential to flatten out current surges. It should be noted that a leisure battery is designed to deliver a lesser current over longer periods which is often referred to as 'cycling', or 'deep cycling'. Leisure batteries are constructed differently to starter batteries to withstand the many cycles of discharging and recharging. The battery locker will take up to a 120 amp hour battery (depending on the manufacturer) **and we would recommend you use a high quality 110 amp hour minimum. The maximum size of the battery housing can be seen in Fig. 1 and 2. However, space is needed above the battery to store the connection cables.**

Fig 1.

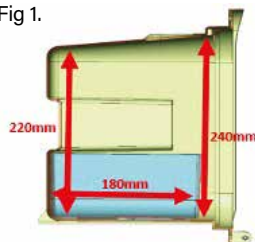
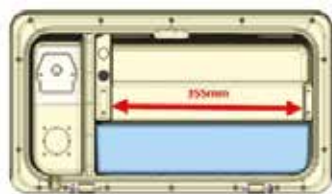

Fig 2.



It should be noted that if using a motor mover the battery should be of an AGM type and capable of at least a 500 amp cold crank current. That is the power the battery can deliver for a given time under certain conditions and is usually referred to as its CCA (cold cranking amps). There are various different methods of measuring the CCA, but the most popular standard in the UK is the SAE (Society of

Automobile Engineers) method.

Always use the battery tray and retaining strap when installing a battery always ensuring fixing across to two points never around the battery.

Below is a list of battery types that can/can not be used. You should always refer to the battery manufacturer's specifications.

- Lead Acid Battery - Can be used. The float charge for a lead acid battery is 13.8V.
- AGM Battery - Yes, as above.
- Gel Battery - No. Typical float charge for a gel type battery is 13.3V, so the recommendation is not to use this type, unless stated otherwise by the battery manufacturer.
- Lithium Battery - Yes, but the battery must have it's own 'Battery Management System' (BMS). The BMS will regulate the charge voltage and current so as not to overcharge the battery.

For full verification of quality leisure batteries please refer to the "NCC verified

leisure battery scheme.”

www.thencc.org.uk/consumer-advice/verified-battery-list

Lithium Battery Guidance

It is fundamental that a Lithium battery has its own 'Battery Management System' (BMS) built into it. Lithium batteries may not be suitable for every owner. Thought should be given regarding the use of the caravan and needs of the battery. For example, Lithium Batteries may not support the use of a large motor mover. Additionally, lithium batteries give lower performance in cold and adverse weather conditions.

The NCC has written some guidance notes (GN19) on Lithium Batteries and this can be found on their website.

CAUTION: Take care not to expose the battery to sparks or naked flames, as explosive gases may be present.

NOTE: As with mains supply, switch off all appliances and lights before disconnecting the battery.

Warning

Never leave a leisure battery in a discharged (flat) condition as this will cause the battery plates to 'Sulphate' rendering the battery useless and also invalidate any warranty. Lead-acid batteries must be left in fully charged condition, when left idle for long periods a top-up charge must be performed periodically. These rules apply to all types of lead-acid batteries.

Generators

When using a generator ensure that the actual output voltage does not exceed the rated generator output voltage, and the rated input voltage of the consumer unit, otherwise internal damage to the unit could occur.

Before starting the generator ensure that the RCD lever is in the off position.

NOTE: Refer to the manufacturer's instruction book before use.

NOTE: It is important as with all power supplies that the generator is run up to speed and allowed to settle before switching it onto the system.

Connecting services - Control panel

Control panel (where fitted)



- Master 12 volt ON/Off Switch
- Pump ON/OFF Switch/Pump Run Indication
- 12 volt Lighting Switch
- Awning Light Switch
- Voltmeter Switch

When the caravan is connected to the car, the car supply is connected automatically. For your convenience the master 12 volt switch, switches all the 12 volt circuits from the caravan except for the circuits requiring dedicated supplies from the battery, such as fridge ignition or alarm if fitted.

The pump switch, switches the supply to the pump, but the pump light is illuminated all the time.

Seattle control panel (where fitted)

User Manual - not all functions are available



Overview:

The Seattle control panel allows the user a central point to check:

- Leisure battery voltage
- Leisure battery current
- Load current

- Mains current
- Solar current
- Internal temperature
- Water level
- Battery source
- Pump source

The Seattle control panel also allows the user to:

- Switch on/off all non-essential electrical appliances/accessories
- Switch on/off the lights
- Change the pump mode
- Switch on/off the pumps
- Force the internal pump to run (for purging pipes)
- Switch on/off the awning light
- Calibrate water/waste probes

The Seattle control panel also has optional audio and visual warnings for:

- Battery overvoltage/current alarms
- Battery under voltage alarms
- High solar current alarm
- Communication error
- Empty water tank
- Fuse blown alarms



NOTE: Some of the options or features highlighted above are not available on selected models.

Function Buttons:



Navigation Buttons:



Use the  and  buttons to navigate up and down through menus. Pressing the button will allow the user to enter menus or change settings (If further settings are available).

Master Button:



When the Master Button is pressed the control panel will switch power to all non-essential accessories. Some features require the Master Button to be switched on to be enabled.

NOTE: Essential appliances may remain powered when the master switch is off, for example the Alarm or Fridge.

Lights Button:



When the Lights Button is pressed the control panel will switch power to all the interior lights.

NOTE: If the master switch is off this button will not function.

Pump Button:



When the Pump Button is pressed the control panel will enable/disable the water pumps. If the water level is 0% the pump may not run, holding down the Pump Button forces the internal pump to run regardless of tank level.

NOTE: If the master switch is off this button will not function. See "notifications and warning" section for pump running notification.

Connecting services - Control panel

Awning Button:

When the Awning Button is pressed the control panel will switch power to the exterior awning light.

Fridge Button:

When the Fridge Button is pressed the control panel will switch power to the fridge.

NOTE: If the master switch is off this button will not function.





Main Page Descriptions:

NOTE: Some menu pages may be unavailable on selected models.

Main Page - Clock Display:



The Clock Display main page is displayed by default. The control panel will return to the main page when left to idle. The main page displays the time as well as any relevant notifications or warnings that are present. The time can also be set from this page, to set the time please follow the instructions below:

1. On the main page hold  for 3 seconds until the hours being to flash.
2. Keep pressing  or  to change the hours
3. Press  to set the hours, the minutes will now flash
4. Keep pressing or to change the minutes
5. Press  to set the minutes and finish setting the time

Leisure Battery Voltage Display Page:

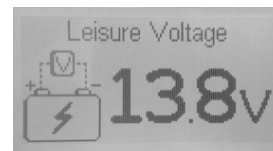

This page displays the leisure battery voltage. If a 230V mains supply is connected then the charging voltage of the leisure battery will be displayed. If the leisure battery is being charged then a lightning icon will appear in the battery.

To increase the accuracy of the battery voltage reading, switch the "Master Switch" off, this will reduce the load and give a better indication of the batteries voltage level.

NOTE: See the "Notifications" section in the User Settings to enable/disable the high and low voltage notifications for the Leisure Battery

Internal Temperature Display Page:



This page displays the internal temperature. It is measured by a sensor inside the control panel and displayed on the screen in degrees Celsius by default.

Water Level Display Page:





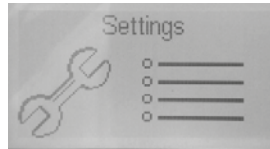

This page displays the current water level in the leisure vehicle as a percentage. If the “Low Water” notification is enabled the user will receive a notification when their water tank levels drop below 10% by default.

User Settings:





This page is the user settings menu page, pressing the  button will enter the user settings and allow some settings to be altered, such as display settings, sound settings and which notifications are enabled etc. There is a description for the different settings, options and how to navigate the menus below.



Navigation:

- Scroll through the settings with the  and  buttons.
- The user settings menu has drop-down menus, pressing the  button on a setting that has the  icon (Highlighted in the image below) will open the drop-down menu and allow settings to be changed.





- To edit a setting, highlight it then press the  button. Depending on the setting the user may be required to use the  and  buttons to scroll through the different options available to a setting.
- Once the required option has been selected, press the  button to confirm the value change.
- To exit the User Settings menu scroll to the bottom of the page and press  on “Save and Exit”.

Display Menu:

Pressing  on the Display setting will open the Display drop-down menu.



Contrast:

Pressing  on will allow the contrast value to be changed using the  and  buttons. Increasing the contrast will make the screen darker overall,

Connecting services - Control panel

decreasing the contrast will lighten the screen overall. At its minimum (0) and maximum (63) the screen will become almost unreadable. Pressing the  button will save new contrast value.

Standby:

Changing this setting alters the amount of time the control panel will stay lit before it goes into standby mode. Press  to select the setting and then the  and  buttons to select the time in 5s increments.

Return to home:

This setting is toggled On/Off using the  button. When this setting is enabled the control panel will return to the main clock screen when it goes into standby.

Sound Menu:

Pressing  on the Sound setting will open the Sound drop-down menu.

Key Tones:

Pressing the  button enables and disables the key tones on the control panel. When this setting is disabled pressing buttons will no longer make a noise.

Alarm Tone:

Pressing the  button enables and disables the alarm tones on the control panel. When this setting is disabled alarms will no longer make a noise.

Temperature Unit:

Pressing the  button switches the default temperature setting between degrees Celsius (°C) and degrees Fahrenheit (°F).

Hide Advice:

Pressing the  button enables/disables whether advice pages are displayed after an alarm has been acknowledged. The advice pages give a slightly more detailed explanation on the cause of the alarm.

LBat Low Volt:

Pressing the  button enables/disables the Leisure Battery Low Voltage notification. Disabling this will no longer inform the user when the Leisure Battery voltage goes below 11V.

LBat High Volt:

Pressing the  button enables/disables the Leisure Battery High Voltage notification. Disabling this will no longer inform the user when the Leisure Battery voltage goes above 14.9V.

Notifications:

The list below contains all of the settings available in the notifications menu.

High Load:

Pressing the  button enables/disables the High Load notification. Disabling this will no longer inform the user when the leisure vehicle is drawing over 18A.



Low Water:

Pressing the  button enables/disables the Low Water notification. Disabling this will no longer inform the user when the water levels in the water tank get to 10% or below.

High Mains:

Pressing the  button enables/disables the High Mains notification. Disabling this will no longer inform the user when more than 16A is being drawn from the mains supply.

Pump Running:

Pressing the  button enables/disables the Pump Running notification. Disabling this will no longer inform the user when the pump is running.

High LBat Load:

Pressing the  button enables/disables the High Leisure Battery Load notification. Disabling this will no longer inform the user when the Leisure Battery's load is over 20A.

High Solar Load:

Pressing the  button enables/disables the High Solar Load notification. Disabling this will no longer inform the user when the solar panel is providing over 15A.

Fuse Alarm:

Pressing the  button enables/disables the Fuse Alarm notification. Disabling this will no longer inform the user when a fuse has blown.

Overload Fault:

Pressing the  button enables/disables the Overload Fault notification. Disabling this will no longer inform the user when a FET Overcurrent has occurred.

Mains Removed:

Pressing the  button enables/disables the Mains Removed notification. Disabling this will no longer inform the user when the mains have been removed.

Engine Running:

Pressing the  button enables/disables the Engine Running notification. Disabling this will no longer inform the user when ignition signal is present (Engine Running).

Comms Fault:

Pressing the  button enables/disables the Comms Fault notification. Disabling this will no longer inform the user when there are communication faults between the control panel and other products communicating over the LIN network.

High Waste:

Pressing the  button enables/disables the High Waste notification. Disabling this will no longer inform the user when the waste levels in the waste tank get to 90% or above.

NOTE: Some settings/options may be unavailable on selected models.



Connecting services - Control panel

Water/Waste Probe Calibration Guide:

The most common fault with the water/waste level monitors is due to the probes being incorrectly calibrated. We have made improvements to the calibration routine to make it simpler to follow as well as giving some diagnostic values that can be used at a glance to check that the calibration has been successful. This calibration routine is present on Seattle Firmware of 4.1.1.0 and above.



The calibration method is the same for both the Water level probe and the Waste level probe. Ensure that the Master is enabled before attempting to calibrate the water/waste probes. Please follow these steps to complete the calibration:



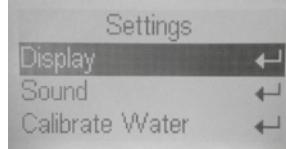

The Water/Waste Calibration Functions are now in the Settings Menu, using the  and  buttons navigate to the "Settings" menu displayed on the left.

Press the  button to enter the Settings Menu.

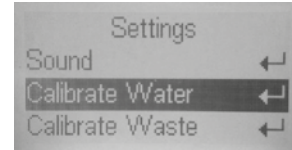

When in the Settings Menu use the  and  buttons to navigate down to "Calibrate Water" or "Calibrate Waste", whichever needs calibrating.



If the Water Probe needs calibrating, press the  button on the "Calibrate Water" option to open this menu.

The next steps are identical when calibrating either the Water or Waste probes.

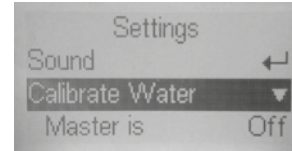

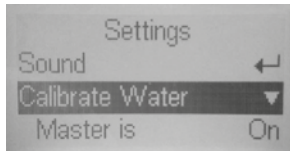

When the required probes calibration menu has been opened, there will be a indented line called "Master is" which will inform you if your master is switch On or Off.

For the calibration routines to work the Master must be switched On.

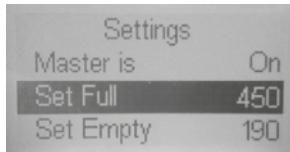

If the "Master is" line says "Off" then press the Master Button  to enable the master, this will provide power to the water/waste probes



Using the  button navigate down to "Set Full", this option will set the full value of the tank.

Ensure that the Master is On and that the water tank is filled to the desired capacity.

Press the  button to set the water probe's new full value.

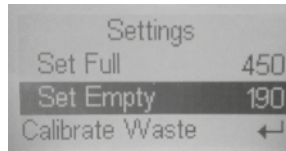

Using the  button navigate down to "Set Empty", this option will set the empty value of the tank.

Ensure that the Master is On and that the water tank is completely empty.

Press the  button to set the water probes new empty value.

Now that the full and empty values have been set the Control Panel will be able to correctly interpret the values sent by the water probes and will be able to display more accurate information.

Troubleshooting

The Set Full and Set Empty values are the very low:



If the "Set Full" or "Set Empty" values are set to a low number such as between 0 - 10 check that the Master has been

enabled as the master must be switched On for the Probes to calibrate.

If the Master is On and the Set Full/ Empty options still displays a low value (0 - 10) then there may be an issue with the probe, either it's not receiving power, not sending the correct signal or the connection to the control panel is faulty. In either case you should contact your dealership.

The Set Full and Set Empty values are the same/very similar:



If the Full and Empty values displayed are the same, for example if they both read 192 or one reads 190 and the other 194, then this shows that both the Full and Empty values have been calibrated using the same water level in the water tank.

Ensure that the tank is full when pressing the  button on "Set Full" and then ensure that the tank is empty when pressing the  button on "Set Empty".

The Calibrate Water or Calibrate Waste dropdown menu isn't shown:

Connecting services - Control panel

The dropdown water/waste calibration menus will only be present in the user settings if the respective water/waste probes have been enabled in Seattle Control Panel software.

The Seattle Software may also be from a previous version, to check the software version use the  or  barrows to scroll to the bottom of the user settings and check the section named "Firmware". Only versions 4.1.1.0 and above contain this new calibration routine.

Firmware:

The Firmware option does not have any settings as it just displays the current version of Firmware that is installed onto the control panel.

Save and Exit:

Selecting this option will save any changed settings and then go back to the user settings page in the main menu.

Notifications and Warnings:









There are a number of icons which can















appear at the top of the main clock page. When a new notification or warning is triggered it may be accompanied by a pop-up alarm screen if the correct settings are enabled. When this occurs the control panel will flash and beep until the warning is acknowledged by pressing the  button.

In the event of a Whale lockout, attempt to turn the heater on and follow the on screen instructions. If this fails to clear the fault then please consult the Whale user manual for more detailed information.





Please see table below for the name and description for each icon:

Icon	Name	Description
	Low Leisure Battery Voltage Warning	Displays when the Leisure Battery Voltage is lower than 11V (Default value)
	Low Vehicle Battery Voltage Warning	Displays when the Vehicle Battery Voltage is lower than 11V (Default value)
	High Leisure Battery Voltage Warning	Displays when the Leisure Battery Voltage is higher than 14.9V (Default value)
	High Vehicle Battery Voltage Warning	Displays when the Vehicle Battery Voltage is higher than 14.9V (Default value)
	High Leisure Battery Current Warning	Displays when the Leisure Battery Current is higher than 20A (Default value)
	High Vehicle Battery Current Warning	Displays when the Vehicle Battery Current is higher than 20A (Default value)
	High Load Current Warning	Displays when the Load Current is higher than 18A (Default value)
	High Solar Panel Current Warning	Displays when the Solar Panel is providing more than 15A (Default value)
	High Mains Current Warning	Displays when the mains supply is drawing more than 16A (Default value)

	No Communications Warning	Displays when there are communication faults in the LIN network
	Ignition Notification	Displays if the engine is running
	Fuse Blown Warning	Displays if a fuse has blown
	Draining Leisure Battery Notification	Displays if the leisure vehicle is being powered from the Leisure Battery
	Draining Vehicle Battery Notification	Displays if the leisure vehicle is being powered from the Vehicle Battery
	Mains Connected Notification	Displays if the leisure vehicle is connected to a mains supply
	FET Overcurrent Warning	Displays if there is an overcurrent fault from the control panel
	Pump Running Notification	Displays if the pump is running
	Thermistor Icon	Displays if there are faults with the temperature sensors
	Waste Level High Warning	Displays if the waste level is at 90% or over (Default value)
	Water Level High Warning	Displays if the water level is at 10% or under (Default value)
	Space Heater General Fault	Displays if there is a Whale Space Heater General Fault
	Space Heater Ignition Fault	Displays if there is a Whale Space Heater Ignition Fault
	Space Heater Over-heat Fault	Displays if there is a Whale Space Heater Over-heat Fault

Connecting services - Control panel

	Space Heater Voltage Fault	Displays if there is a Whale Space Heater Voltage Fault
	Space Heater Air-pressure Fault	Displays if there is a Whale Space Heater Air-pressure Fault
	Space Heater Misc. Fault	Displays if there is a Whale Space Heater Misc. Fault
	Water Heater General Fault	Displays if there is a Whale Water Heater General Fault
	Water Heater Ignition Fault	Displays if there is a Whale Water Heater Ignition Fault
	Water Heater Over-heat Fault	Displays if there is a Whale Water Heater Over-heat Fault
	Water Heater Voltage Fault	Displays if there is a Whale Water Heater Voltage Fault
	Water Heater Air-pressure Fault	Displays if there is a Whale Water Heater Air-pressure Fault
	Water heater Misc. Fault	Displays if there is a Whale Water heater Misc. Fault

Warranty:

If you believe that there is problem with your control panel please contact your dealership who will be able to help.

NOTE: Not all warning/notifications may appear due to differences in leisure vehicle specifications, the default values may be altered depending on the vehicle specification

ALDE central heating and hot water system

Full instructions on the use of this system are included in the information pack you received with your caravan and we would strongly recommend you read them thoroughly before using the boiler.

Warning Quick Start Guide - 3030 Colour Touch

This quick start guide allows end users to confidently use the core features of their Alde control panel. See the operating and installation instructions for the Alde control panel for more details.

Important!

Please read the operating instructions for the Alde 3030 Compact HE boiler before using the system.

Warning

Hot Water

High water temperatures above 49°C can cause serious scaling, and in extreme cases even death. The heating system can supply water at a temperature above 85°C.

If showering, ensure that the cold-water supply is full. If the pump has to switch tanks or starts to run dry, extremely hot water will be supplied at the shower head or supply tap.

Ensure that no other water sources are used whilst showering, as this may reduce the cold water supply pressure, resulting in elevated temperatures.

Before using a hot tap or shower, let the water run until the temperature is safe and stabilised. Check the water temperature before entering a shower.

Never allow a child to shower unattended.

If cold water supply is interrupted or stopped, the pump and system can still 'run on' for a few seconds, resulting in water being delivered at elevated temperatures.

Caravan equipment



Starting the system

1. Both the control panel and boiler are off.
2. To start the system, press the Power button on the control panel. The Splash Screen is displayed and green LED is lit. The boiler will now start with the previously saved settings (factory settings by default).

The system will now be drawing variable 0.2-1A of current from the 12V supply.

Status screen











When the control panel enters sleep mode, the status screen appears. Tap the respective symbol on the status screen to reach its submenu. Press the "MENU" button to reach the Settings menu.

NB: If Standby Screen is set to "Dark" in Backlight settings, the Standby Screen will not be displayed, the screen will be dark unless touched.



Symbol description of the top row of the status screen (Fig.1)

NOTE: Not all functions listed are available.

	Operating messages. Displayed if temporary service interruption occurs; this is not an error. Await.
	Information. Flashes when there is an information message.
	230V. Electricity (230V) is connected to the boiler.
	Day Mode. Appears when the feature is on and turns green when it is active.
	Night Mode. Appears when the feature is on and turns green when it is active.
	LPG bottle full/empty*. Appears if a DuoControl is installed. Black bottle = Gas available. Red bottle = One bottle empty.
	EisEx*. Appears if EisEx is turned on and turns green when active.
	Engine heating*. Shown if the engine heater is installed and turned on, and turns green when active.
	Anti-bacteria. The boiler's automatic bacterial elimination setting is running.
	High altitude mode. Flashes if the high altitude mode is active.

Caravan equipment

Main menu

Press MENU button to access the Main Menu from the Standby Screen or Settings Menu. The screen will revert to the Standby Screen after 30 secs if untouched.

Fig 2.



1. Standby Screen. Press MENU button.
2. Main Menu.
 - a. What's Activated Menu. [Not displayed if no activated functions are detected.]
 - b. Settings Menu



Desired Room Temperature

The desired room temperature can be set from 5 to 30°C, in 0.5 increments.



The World Health Organisation recommends a room temperature of 18–24°C for healthy living.

1. The current desired room temperature is displayed.
2. Adjust by pressing Plus or Minus button.



Domestic Hot Water

The boiler has a built-in water heater capacity of about 8.5 litres. The boiler can be used even without fresh water being in the heater. There are three different settings for hot water: No hot water, normal operation and boost (prioritised hot water).





- No hot water or normal operation. Press the on/off button on the screen under hot water to switch between no hot water production and normal hot water production.

- Boost, (prioritised hot water production). Tap the slider to the right of the text that reads "Boost 30 minutes". The boiler will now prioritise the production of hot water for 30 minutes. After 30 minutes have passed, the boiler returns to its previous setting. Prioritised hot water production is recommended for increased hot water demand.



- In a good summer, for example, lower the desired temperature on the control panel to around 10°C. The central heating will not circulate (unless the temperature drops to 10°C), but you can still control hot water.

Symbol description of the top row of the status screen (Fig.2)

	<p>Indoor temperature shows the current temperature and whether the circulation pump is active (🔄). Tap the icon to change the desired temperature.</p>
	<p>Zone icons (dual zones). Displays the current temperature and whether the circulation pump is active in the zone (🔄). Tap the icon to change the desired temperature.</p>
	<p>Light*. Start, turn off, or dim the AC lighting (only with Truma AC).</p>
	<p>Energy. Shows the energy source used; the flame turns red when gas is in use, and the flash turns yellow when electricity is in use. Tap the icon to select and prioritise energy source, and to set load monitor* and high altitude mode.</p>
	<p>Hot water. Indicates whether hot water production is on "boost" (💧) or tuned off (🌡️). Press the respective controls to start/switch off or increase hot water production. The thermometer fills up entirely when the hot water reaches boost temperature.</p>
	<p>Outdoor temperature*. If an outdoor sensor is installed, the current outdoor temperature is displayed.</p>

NOTE: Not all functions listed are available.

Caravan equipment



Energy sources

The boiler can be powered either by gas or electricity, or both at the same time. The fastest heating is obtained by using both power sources at the same time, as the overall power available will be greater. It is also possible to prioritise which energy source to use.

Heating with electricity

The consumption selected in the menu is the maximum consumption permitted, i.e. the boiler does not use more power than is required.

- Tap the "Max electricity" menu bar to open the electric power setting menu.
- Increase or decrease the maximum permissible electrical power between 0-3kW. 0kW mean electric operation is switched off.
- Confirm your selection by pressing the "Set" button.

Heating with gas

Tap the slider on the "Gas" menu bar to start and shut off gas operation.

Shutting down the system

To save energy, the control panel only updates the boiler after the last adjustment is made. Wait 10 secs before shutting down the system to ensure the boiler is updated.

1. Press the Power button again. The screen goes dark, the green LED is unlit. The system is off.

Maintenance

The Alde control panel requires no maintenance, other than cleaning of the screen as needed. Use a microfibre cloth to clean the touchscreen.

Troubleshooting

Any error messages will be displayed on the Standby Screen. Error messages can be cleared by switching off 12V supply to the boiler for 10 seconds.

The system is completely dead, the control peak is blank

- Check the 20 mm T3.15 Amp glass fuse in the boiler. This is located under the lid of the black plastic service hatch, in a green plastic fuse holder.
- Check the 12V supply to the boiler, it should be above 12V
- Check the 12V cable is plugged into the boiler. Check the cable is plugged into the Alde control panel

"Panel failure 1 & Panel failure 2"

- Moisture is trapped in the control panel.
- Remove the Alde control panel from the vehicle and air in a warm, dry place overnight.

"Gas failure"



- Out of gas or gas is not igniting.
- Check the gas cylinder is full. Try a different gas cylinder, ensuring it is propane gas.

“Overheat red fail” or “Overheat blue fail”

- Bleed the system of air.
- Check the fluid level in the expansion tank. It should be 1cm above Min mark when cool.
- Check the circulation pump is responding.
- Wait 15 mins for the fluid to cool down.

“Overheat PCB”

- Failsafe in boiler has triggered.
- Check the fluid level in the expansion tank. It should be 1cm above the Min mark when cool.
- Check the boiler compartment is ventilated, and that the vents are unobstructed. Do not place stowage in the boiler compartment.

“Connection failure”

- Loose connection between Alde control panel and boiler.
- Unplug cable at the control panel and boiler, then carefully plug back in.
- Check there is slack on the cable at the control panel, but not excessive weight from free-hanging/unmanaged cable.

“Low battery”

- 12V supply to boiler has dropped below 10.5V, possibly causing system brownout.
- Automatically clears when 12V supply reaches 11V.

If problems persist, please contact Alde, or your dealer or installer.

For our frequently asked questions, or download all instruction manuals, please visit our web site at: www.alde.co.uk or watch a demonstration on YouTube - “How to use the Alde 3030 control panel”

Caravan equipment

Aventa Air Conditioning Unit Correct Use

The Aventa compact (plus) 2.G / Aventa comfort 2.G roof-mounted air conditioning system is approved only for installation on the roof of a motor home (motor caravan) of vehicle class M1 and motor trailers (caravans) of vehicle class O with legally prescribed safety ventilation in accordance with EN 721. It is intended exclusively for use in the private sector and for air conditioning of the living area. If possible, operate the air conditioning system with the windows and doors closed.

Installation, dismantling, repositioning

Only competent, trained personnel (experts) may install and repair the Truma product and carry out the function check with consideration of the installation and operating instructions and the current recognised rules of engineering. Experts are persons who, based on their professional training, their knowledge of and experience with Truma

products and the relevant standards, are able to carry out the required work properly and recognise potential hazards.

Safety through maintenance and servicing

- Installation, maintenance and repair only by experts who are familiar with the dangers of handling electrical appliances, refrigerants and air conditioning systems. Incorrect work can result in considerable hazards.

- In particular, do not screw in any long screws or similar near the air conditioning system, as this can damage the air conditioning system and cause refrigerant to escape.

- Opening the system, loosening the fixing points, assembly, disassembly, inspection and repair only by an expert.

- Steam-based and high-pressure cleaners must not be used.

- When cleaning the vehicle, ensure that no water gets into the air conditioning

system (e.g. do not spray water directly into openings in the air conditioning system).

- Do not reach into the appliance; risk of burns from hot parts.

Condensation trap

The condensation is led away via the roof of the vehicle. For this purpose, there are holes on the underside of the external unit through which the condensate drains.

NOTE: Puddles of water may form under or next to the vehicle if the air conditioning system is operated for long periods.

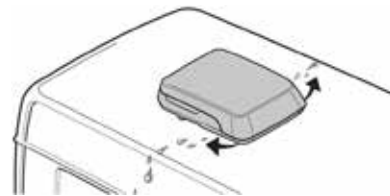

Fig 1.

Air distribution in the interior

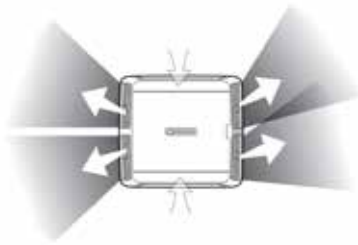

Fig 2.

The room air is drawn in via the air distributor. In cooling mode, the warm room air is cooled by the air conditioning system and flows directly into the interior via the air distributor. In heating mode, the cool room air is heated up. The air distributor is located beneath the ceiling.

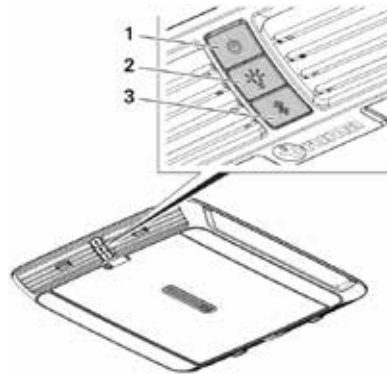

Fig 3.

1. On/Off switch
2. Light switch for ambient lighting (Premium air distributor only)
3. Pairing button

NOTE: 30 seconds after switching on, the illumination of the pressed button is faded out so as not to disturb in the dark.

The air distributor has four individually adjustable outlets. This allows the airflow to be metered and distributed evenly and

draught-free throughout the vehicle. The air distributor is so flat that it takes up hardly any valuable space.

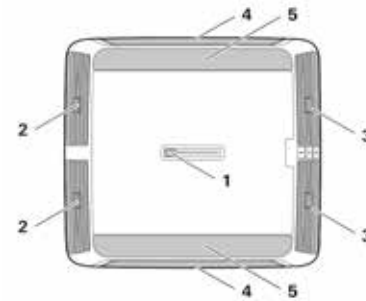

Fig 4.

1. Slider (air distribution front / rear)
2. Air adjustment (at the back in the direction of travel)
3. Air adjustment (at the front in the direction of travel)
4. Air adjustment side panels (mortar grey or grey beige)
5. Air adjustment panels (winter white or pure white)

Caravan equipment

The air flow can be metered between the front and rear areas of the vehicle.

Ceiling/floor

The air flow can be directed from the ceiling to the floor.

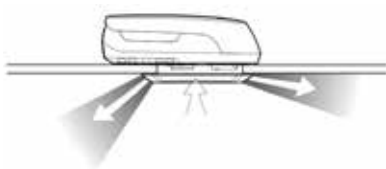

Fig 5.

Right/left (premium air distributor only)

There are two individually adjustable air outlets at the front and rear.

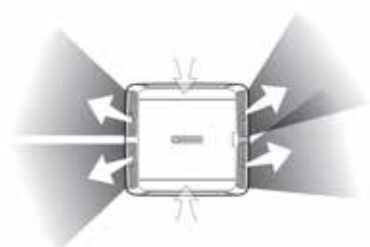

Fig 6.

Operation

Aventa 2.G remote control (Bluetooth)

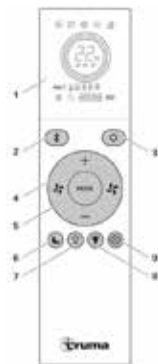

Fig 7.

1. Display (see Fig. 8)
 2. Pairing button (Bluetooth)
 3. On/off button
 4. Device control (navigation buttons):
Fan speed (left / right)
Target temperature (up / down)
 5. Operating mode (cooling / heating / ...)
 6. Night mode
 7. Ambient lighting off (press once),
darker (press and hold) 1
 8. Ambient lighting on (press once),
brighter (press and hold) 1
 9. Automatic mode
- 1: Premium air distributor only



Fig 8.

1. Automatic mode
2. Heating mode
3. Cooling mode
4. Circulation mode
5. Dehumidification mode
6. Target temperature (°C)
7. Ventilation level
8. Activity indicator, cooling / heating / ventilation

9. iNet X status
10. Fault code
11. Bluetooth status
12. Night mode
13. Time
14. Battery status

NOTE: The symbols in the display become visible depending on the respective setting.

Notes on using air conditioning systems

Check current consumption

Truma recommends a power supply designed for 10A.

During operation under standard conditions, the current consumption is below this value.

- Before switching on, check that the fuses at the campsite are adequate.
- Check whether the voltage source used for combined operation of the

air conditioning system and the other connected devices is sufficiently fused.

Inclined position

To prevent the compressor from running dry and premature wear, the air conditioning system must not be operated on inclines greater than 8 % / 4.5°.

NOTE: Material damage caused by parking the vehicle on a sideways incline.

Condensate drainage is not guaranteed. The service life and function of the compressor are impaired.

-Park the vehicle with a maximum transverse and longitudinal inclination of 8 %.

Optimising the room climate

In order to obtain a healthy room climate, the difference between the inside and outside temperatures should not be too great.

During operation, the circulated air is cleaned and dehumidified.

Caravan equipment

Dehumidifying moist air creates a pleasant indoor climate even if the temperature differences are not great.

- The vehicle must be properly ventilated before starting the air conditioning system in order to remove accumulated warm air from the vehicle.

- Keep all doors and windows closed during operation to prevent condensation forming on the air distributor. This also minimises energy consumption.

- Direct the air flow in the room so that it keeps the air in the room moving.

Settings for rapid cooling

- Set the fan to the highest level
- Move horizontal air distribution to centre position between front and rear
- Place vertical air distribution on ceiling

Switching the air conditioning system on and off

The air conditioning system can be

switched on and off using the remote control.

NOTE: The air conditioning system can also be controlled via control panels installed in the vehicle, e.g. the optional iNetX panel. If a third-party control panel is installed, refer to the operating instructions.

If the remote control is not at hand or the batteries in the remote control are flat, the air conditioning system can also be switched on and off manually using the on/off switch on the air distributor. The air conditioning system runs at 22 °C after switching on in automatic mode.

Switching on the air conditioning system (air distributor)

Press the  button on the air distributor (Fig. 3) for one second.

The LED on the  button lights up for 30 seconds and then goes out.

The air conditioning system is switched on. The air conditioning system starts with the following settings: Automatic

mode, temperature: 22 °C.

Switching off the air conditioning system (air distributor)

Press the  button on the air distributor (Fig. 3) for one second

The LED on the button  goes out.

The air conditioning system is switched off.

Automatic restart after an interruption to the power supply

If the air conditioning system is disconnected from the power supply without being switched off manually, it switches on again automatically the next time it is connected to the power supply.







Even after a device-related switch-off due to an unstable power supply, the device restarts automatically as soon as a stable power supply is restored.

Operating modes

Operation using the Bluetooth remote control is described below. Operation

with the Truma iNet X Panel or the Truma App is described in the respective operating instructions.

The air conditioning system has the following operating modes:

Symbol	Operating mode
	Cooling mode
	Heating mode
	Automatic mode
	Air circulation mode
	Dehumidify
	Night mode

Cooling mode

In cooling mode, the room air is dehumidified and cooled.

- Press the button once or several times until the ❄️ symbol appears on the display.

The activity indicator (Fig. 8) changes to

blue while the air conditioning system is in cooling mode.

The activity indicator changes to white when the set room temperature is reached.

The circulated air fan continues to run in order to provide ventilation.

NOTE: Cooling mode can be activated with a slight time delay once cooling mode has been activated.

The air is dehumidified during cooling. If the air humidity in the vehicle is extremely high at the beginning of the cooling procedure, moisture can build up on the underside of the air distributor. In this case:

- Keep doors and windows closed
- Select the highest power level

Heating mode

In heating mode, the air conditioning system is operated as a heat pump and heats the interior.

- Press the **MODE** button once or several times until the ||| symbol appears on the display.

The activity indicator (Fig. 8) changes to red while the air conditioning system is in heating mode. The activity indicator changes to white when the set room temperature is reached.

The circulated air fan continues to run in order to provide ventilation.

NOTE: heating mode can be activated with a slight time delay after heating mode has been activated.

Automatic mode

In automatic mode, the air conditioning system is operated in cooling or heating mode depending on the room temperature in order to achieve the set room temperature.

- Press the **MODE** button once or several times until the Ⓐ symbol appears on the display.
- Alternatively, press the Ⓐ button for

Caravan equipment

direct selection.

- The activity indicator (Fig. 8) changes to red while the air conditioning system is in heating mode.
- The activity indicator changes to blue while the air conditioning system is in cooling mode.
- The activity indicator changes to white when the set room temperature is reached.

NOTE: In automatic mode, the cooling/fan levels are automatically adjusted so that the vehicle is initially cooled down quickly and then, as the target temperature is approached, is reduced to such an extent that the air conditioning system operates as quietly as possible.

NOTE: Automatic mode can be activated with a slight time delay once cooling mode has been activated.

Air circulation mode



In circulation mode, the interior air is circulated.

- Press the **MODE** button once or several times until the  symbol appears on the display.

Night mode

In night mode, the inside and outside fans run at a low speed and are therefore very quiet. Night mode deactivates the selected fan level setting (low, medium, high) and activates cooling or heating mode.



- Press the  button.

The display shows the symbols  and . Night mode is set.

Press the button again to switch off night mode. The air conditioning system is then operated again with the previous settings.

Dehumidify

Dehumidifying mode reduces the humidity in the room. The selected fan level setting (low, medium, high) is deactivated and cooling mode is activated.







- Press the **MODE** button once or several times until the symbols  and  appear on the display.





The air conditioning system dehumidifies the room.

Dehumidification is ended by pressing the **MODE** button. The air conditioning system is operated with the previous settings.

Setting the fan

The fan for the indoor air has three operating levels

Symbol	Operating level
(none)	Automatic fan control
	low
 	medium
  	high

- Press the  or  button once or several times to select the desired operating level. The  button reduces the fan speed and the  button increases it.

The desired operating level of the fan

is shown on the display. The desired operating level is set.

NOTE: In cooling / heating mode, not only the fan speed is adjusted, but also the compressor speed.

NOTE: In "Automatic fan control" mode, the fan speed is automatically controlled by the air conditioning system depending on the temperature difference to the room air.

Setting the room temperature

The room temperature can be set in a range from 16 °C to 30 °C in increments of one degree.

- Set the room temperature with the + and - temperature selection buttons.

The desired room temperature is shown on the display. The desired room temperature is set.

Cleaning the panels in the air distributor

Depending on the intensity of use, the panels in the air distributor must be

cleaned. We recommend that this is done at least every 12 months.

NOTICE: Operation without panels in the air distributor leads to damage and loss of performance of the air conditioning system.

For trouble-free operation, operate the air conditioning system only with panels.

- Before operation, ensure that panels are inserted in the air distributor.

- Pull both panels off the side of the air distributor as shown.

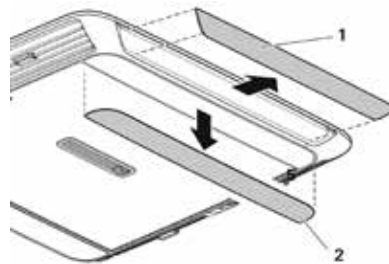

- Remove both panels from the bottom of the air distributor as shown. To do this,

reach into the opening in the side panel and push the lower panel out from the inside.

- Wash the panels under running water.

- Allow the panels to dry.

- Reattach the panels to the air distributor. To do this, push the panels onto the side and bottom of the latches and clip them into place. First insert the lower panels on the inside of the air distributor as shown, then press in on the outside and snap into place as shown.

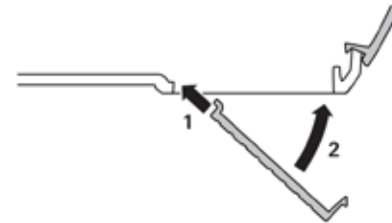

Caravan equipment

Keeping air inlets and outlets clear External unit clearance

The air conditioning system draws in cooling air on both sides of the roof and blows it out to the rear after it has passed through the heat exchanger. To ensure safe operation, the air inlets and outlets must not be obstructed or adjusted. They must be kept free of dirt or leaves, for example, to ensure optimum performance and air flow. Otherwise, the function of the air conditioning system will be impaired and damage may occur.

Keep openings clear of snow during winter operation.

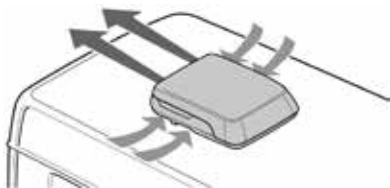



Keep the condensation trap clear

On the roof, the condensate outlets of the air conditioning system must be kept free of obstructions, such as dirt or leaves. If the condensate outlets are dirty, water can enter the interior. Otherwise, the function of the air conditioning system will be impaired and may lead to damage.



Troubleshooting

Error	Cause/Remedy
Appliance not cooling	Thawing process in progress Remote control temperature setting reached or too high
Device not heating	Thawing process in progress (outside temperature between 4°C - 7°C) Outside temperature below 4C
Device cooling/heating inadequately or not at all	Panels dirty, clean panels External air routes soiled/blocked
Moisture on underside of air distributor	Close windows and doors and select high fan level
Water dripping out of air distributor	Condensation trap on external unit blocked Seal between appliance and roof not intact (e.g. faulty seal) System at too much of an angle
Remote control not working	Check the batteries in the remote control and replace if necessary
Appliance not reacting to remote control commands	Remote control out of range Remote control not paired with air conditioning system
Red LED on the  button of the air distributor flashing	There is an error in the control system Switch the air conditioning system off, wait for a short time and then switch it on again. If the red LED remains lit, contact Truma Service. Make a note of the error code displayed on the control panel. It may still be possible to continue operation in air circulation mode
Device switches itself off during operation	Check power supply
White LED on the  button of the air distributor flashing	Bluetooth pairing not possible. Delete superfluous Truma apps and repeat pairing

If these actions do not remedy the problem, please contact Truma Service.

Refrigerator operation

Thetford refrigerator operation

Warning

When your refrigerator has reached its end of life, dispose of the product according to local rules. Do not dispose of the refrigerator with normal household waste. The correct disposal of your old product will help prevent potential negative consequences to the environment and human health.

- When the appliance is first put into operation, there may be a mild odour which will disappear after a few hours.
- Park the vehicle level, particularly when starting up the refrigerator and filling with food before starting a journey.
- The cooling unit is silent in operation.
- The refrigerator will take several hours to reach its operating temperature in the cooling compartment. It is recommended to switch the refrigerator on 8 hours prior to placing food in it.

Cleaning

Warning

Always disconnect the refrigerator from the energy supply before cleaning and servicing it.

Notice

When cleaning, never use sharp cleaning agents or hard or pointed tools to remove layers of ice or to loosen objects which have frozen in place.

- Clean the refrigerator regularly and when it gets dirty using a damp cloth.
- Make sure that no water drips into the seals. This can damage the electronics.
- Wipe the refrigerator dry with a cloth after cleaning.
- Check the condensate drain when necessary. If it is blocked, the condensate collects on the bottom of the refrigerator.

- Make sure that the ventilation grilles in the outer wall of the mobile home or caravan and the refrigerator roof ventilator are free from dust and pollutants. This ensures that the heat generated during operation can dissipate, the refrigerator is not damaged and the cooling capacity is not reduced.

Maintenance

In compliance with the applicable regulations, please note that the gas unit and the connected ventilation ducts must be checked by authorised technical personnel after first use and after every other year for compliance with the European Standard EN 1949. A test certificate has to be issued. **It is the user's responsibility to arrange this test.**

- **The gas burner must be inspected and cleaned as necessary at least once a year. When using liquefied petroleum gas (tank or refill cylinders) the maintenance interval**

is reduced to half-yearly or quarterly.

Keep the evidence of maintenance work carried out on your refrigerator.

▪ **Work on gas and electrical equipment shall be carried out by qualified personnel only.**

It is recommended that this is carried out by an authorised customer services department.

Warning

Many modern cars are equipped with a 'Smart Alternator' and 'Stop/Start' technology. Once the engine has stopped, the fridge may not be supplied power and will turn off. The fridge will have to be manually restarted on 12v operation.

A smart alternator may not supply the required power output at the tow bar electrical connection to run the fridge. This should be checked by an appropriate technician.

We recommend maintenance following

an extended shut-down of the vehicle. Please contact our customer services.

Read the safety instructions and information on use and maintenance of the refrigerator carefully before continuing. This will enable you to use the refrigerator safely and efficiently. Retain this manual for future reference.

For the latest version of this manual, please visit www.thetford.com

Safety

- Keep children younger than 8 years away from the appliance, except under constant supervision.
- Do not allow children to play with the appliance. Children can become trapped and possibly suffocate.
- Do not use the drawer as a step or ladder.
- Use only parts supplied by the manufacturer.
- Do not change or adjust anything on the appliance, unless the change is

authorised by the manufacturer or its representative.

- While driving, it is only allowed to run your refrigerator on gas if the vehicle is equipped with a safety closing device according to the local regulations in force.
- If you smell gas: Directly close the valve of the gas bottle, extinguish any naked flames, do not switch on any electrical devices or lighting, open the windows and leave the room. Then contact the Customer Service Department in your country or holiday location.
- If you smell a pungent odour from the cooling system: Switch off the refrigerator, extinguish any naked flames, provide sufficient ventilation through vents, windows and doors. Then contact the Customer Service Department in your country or holiday location.
- Make sure the awning is well air ventilated, when refrigerator vents are located inside awning.

Refrigerator operation

- Do not block the air vents.
- Do not use the refrigerator on gas when vehicle is located indoors.
- If the supply cord is damaged, it must be replaced by the manufacturer, its service agent or similarly qualified persons in order to avoid a hazard.
- Do not store explosive substances such as aerosol cans with a flammable propellant in this appliance.
- Never open or damage the cooling system at the back of the refrigerator. The cooling system is pressurised and contains substances that can be harmful to your health.
- Let a qualified person perform a yearly inspection of the gas system, the burner area and the combustion seal to repair any damages or malfunctions.
- Never attempt to repair parts of the gas system, the gas flue or electrical components by yourself. The repairs must only be carried out by a qualified technician. Please contact the Customer Service Department for further support and addresses.
- Only use gas which is mentioned on the serial label inside the refrigerator.
- Keep flammable material away from the refrigerator.
- Do not use gas to power your refrigerator in the vicinity of petrol stations.
- As the constant regulation of temperature can not be guaranteed, the refrigerator might not be suitable for proper storage of medications. Refer to the instructions included with the medications.

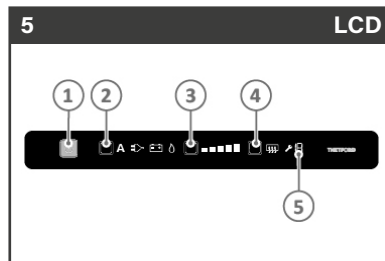
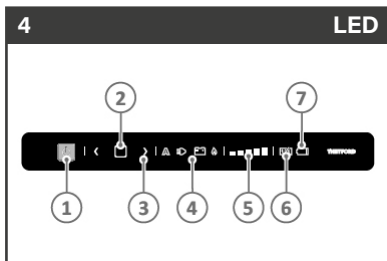
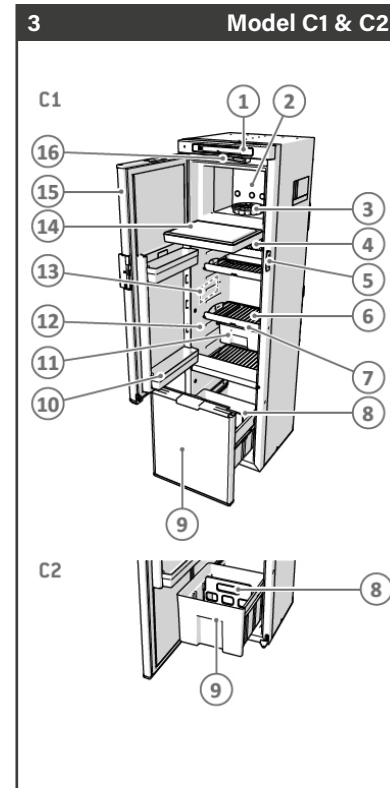
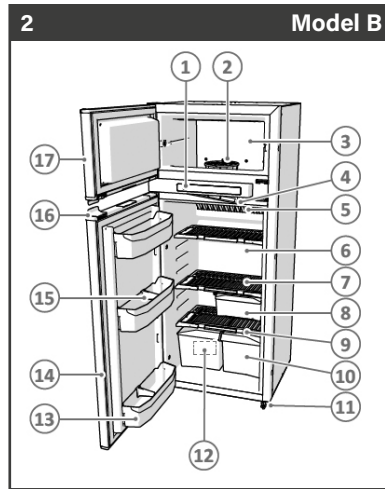
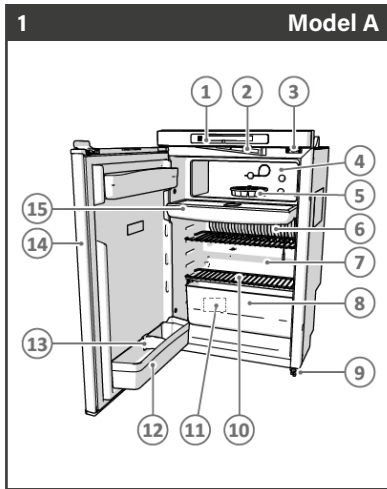

Refrigerator operation

Main components

See images 1 to 5 for a visual reference.

(1) Model A

1. LED control panel or LCD touchscreen
2. Battery pack hatch
3. Door lock
4. Frozen food compartment
5. Cooling fins
6. Fresh food compartment
7. Vegetable bin
8. Security lock (not present on all refrigerators)
9. Storage shelves
10. Serial ID label
11. Door bins
12. Bottle retainer
13. Refrigerator door
14. Frozen food compartment door

(2) Model B

1. LED control panel or LCD touchscreen
2. Frozen food compartment
3. Battery pack hatch
4. Cooling fins
5. Fresh food compartment
6. Storage shelves
7. Slide-out-box (optional)
8. Shelf food retainer
9. Vegetable bin
10. Security lock (not present on all refrigerators)
11. Serial ID label
12. Door bins
13. Bottle retainer
14. Refrigerator door
15. Door lock
16. Frozen food compartment door

(3) Model C1 & C2

1. LED control panel or LCD touchscreen
2. Frozen food compartment
3. Cooling fins
4. Door lock
5. Storage shelves
6. Shelf food retainer (optional)
7. Drawer divider (optional)
8. Drawer for bottles and vegetables
9. Door bins
10. Slide-out box (optional)
11. Fresh food compartment
12. Serial ID label
13. Frozen food compartment door
14. Refrigerator door
15. Battery pack hatch

(4) LED control panel

1. On/off buttons
2. Confirmation button
3. Arrow buttons
4. Energy sources
5. Cooling level indicators
6. Anti-condensation
7. Battery empty (optional)

(5) LCD touchscreen

1. On/off buttons
2. Energy source button
3. Cooling level button
4. Anti-condensation button
5. Error code

Set up your refrigerator

Before using the appliance:

1. Ensure that the DC/AC electricity supply is connected and turned on.
2. Ensure that the gas supply is connected and turned on.

NOTE: When the vehicle is exposed to full sun light, it is strongly recommended to apply proper ventilation in the vehicle.

NOTE: For optimal performance, level your vehicle and switch on the refrigerator 8 hours before placing food inside.

See images 4 and 5 for a visual reference.

Getting the best performance from your fridge

The fridge is designed to run from two sources of power Electric or LPG (gas). The LPG operation is available if no 240v mains connection is present. You should use the 240v operation if connected to mains hook up.

The fridge from starting upon either power source will take anywhere up to 8 hours dependent on the external ambient temperature. This should be factored in when arriving on site and pitching up.

The vehicles 12v operation is designed to maintain the temperature of the fridge and not designed to cool the fridge down. It is recommended prior to a trip (if traveling with the fridge stocked) that the fridge is cooled down 24 hours prior to loading using either LPG or a 240v supply. The tow vehicle once connected will maintain the internal temperature until either LPG or 240v operation is restored. Please note that on journeyers such as overnight car ferries the temperature in the fridge will rise due to the 12v system being inactive.

You should always stock the fridge when it has reached its operating temperature and ideally a few hours before the journey starts. The stock then has time to reach the ambient internal temperature without impacting on fridge efficiency.

Ideally food that can be frozen will help cool down and maintain the internal temperature.

LED

Switch on (LED)

1. Push on/off button (1) and hold it for 1 second. The light in the on/off button turns blue and the last selected settings will light up.

NOTE: Always use the gas connection or 230V to startup and cool.

Select energy source (LED)

2. Push the confirmation button (2) and hold it for 2 seconds until the energy source symbols start to blink.
3. Push the arrow buttons until the desired source is selected. For more information on available sources, see chapter Energy sources.
4. Push the confirmation button with quick touch (press and let go) to confirm your selection.

Refrigerator operation

NOTE: If you do not confirm, after 10 seconds the lights will dim and the selected settings will not be saved.

Select cooling level (LED)

NOTE: We advise to set the refrigerator on cooling level 3, with an ambient temperature between 15°C and 25°C.

5. Push the confirmation button (2) and hold it for 2 seconds until the source symbols start to blink.
6. Push the confirmation button again. The cooling level indicators start to blink.
7. Push the arrow button (3) to select the desired cooling level.
8. Push the confirmation button to confirm your selection. Your control panel should now confirm, and turn off, leaving a blue light in the on/off button.

NOTE: If you do not confirm, after 10 seconds the lights will dim and the selected settings will not be saved.

LCD

Switch on (LCD)

1. Push the on/off button (1). The on/off button turns blue and the last selected settings are shown on the display.

NOTE: Always use the gas connection or 230V to start up and cool.

Select energy source (LCD)

2. Push the confirmation button (2) several times until the desired source is selected. For more information on available sources, see chapter Energy Sources.





Select cooling level (LCD)

NOTE: We advise to set the refrigerator on cooling level 3, with an ambient temperature between 15°C and 25°C.

3. Push cooling level button (3) several times, until the desired cooling level is selected.

Energy Sources

There are four available functions:

	<p>Automatically selects the desired source</p> <ul style="list-style-type: none"> ▪ The control panel shows the A and the best source available.
	<p>230V - Mains</p> <ul style="list-style-type: none"> ▪ This refrigerator is equipped with electronics to ensure optimal cooling performances at all input voltages between 210V and 250V.
	<p>12V - Battery of the vehicle</p> <ul style="list-style-type: none"> ▪ Operating on 12V is only effective while the engine of the vehicle is running. ▪ The performance of the refrigerator when operating on 12V is dependent on the thickness and length of the wiring and the overall installation of the (towing) vehicle. ▪ In case the refrigerator is installed in a caravan, the refrigerator needs a D+ signal (engine running) from the towing vehicle to operate in DC mode while travelling. ▪ The Recreational Vehicle Manufacturer can choose to shut off the 12V option as an energy source.
	<p>Gas - Gas connection of a gas bottle</p> <ul style="list-style-type: none"> ▪ When using gas, make sure the gas bottle valve is opened. ▪ Make sure the control panel is powered from the battery or AA batteries (in the case of a stand-alone model). ▪ When selecting gas, the flame should be ignited within 30 seconds. If the system fails, restart the refrigerator and select the gas source again. For safety reasons it is not possible to ignite the flame within 15 minutes after driving. ▪ From about 1000m above sea level, problems of a physical nature can occur when lighting the gas. This does not mean that the refrigerator is not working properly.

Refrigerator operation

Use of the fresh food compartment

To organise your fresh food compartment as desired, move the storage shelves and door bins in height.

NOTE: To prevent your refrigerator from ice formation always cover liquid products, let warm products cool down before placing them into the refrigerator and do not open the door any longer than necessary.

NOTE: The maximum storage capacity of the drawer is 15kg.

Moving the storage shelves (Model B only)

See image 6 for a visual reference.

- Place a tool with a flat end firmly inside the oval opening of the clip (1).
- Hold the block under the clip with your free hand (2).
- Gently move the tool away from the fridge wall (approximately 30 degrees) while keeping its end on the bottom of the oval opening (3).

- After removing the safety block, rotate the clip upwards to release the shelf (4).
- Move the storage shelf to the desired position.
- Rotate the clip downwards until the shelf snaps into place.
- Place the block at bottom of shelf until you hear a click.

Moving the storage shelves (Model A, C1 and C2)

See image 7 for a visual reference.

The shelves of models A, C1 and C2 are secured to prevent inadvertent entrapment and possible suffocation of children.

Warning

Do not remove the fixed shelves, so children have no space to be entrapped in the fresh food compartment.

If it is necessary to move a fixed shelf, undo the screws that are placed in the shelf near the clamps.

- Turn the plastic clamps of the storage shelf downwards (1)
- Lift that side a bit (2).
- Move the storage shelf to the desired position.
- Place the right side of the corresponding groove and left side in the clamp (3).
- Turn the plastic clamp upwards (4).
- Replace the screws after you have finished.

NOTE: Ensure that the door can still be closed after reorganising shelves and bins.

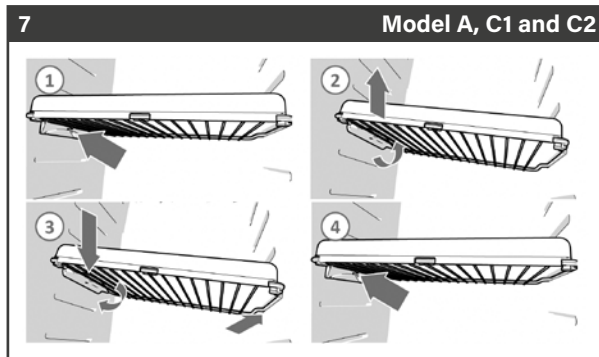
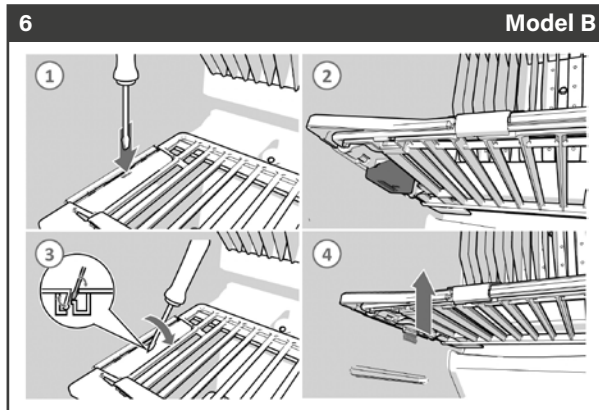

Use of the frozen food compartment

- Use the frozen food compartment to store perishable foodstuffs or frozen foods for short periods.

NOTE: Never keep carbonated liquids in the frozen food compartment.

NOTE: The frozen food compartment temperature cannot be guaranteed if the refrigerator performs in a vehicle interior temperature below 10°C, food might defrost.

NOTE: Never eat ice-cubes or popsicles directly out of the frozen food compartment. This can cause burns.

While Driving

NOTE: While driving, it is only allowed to run to your refrigerator on gas if the vehicle is equipped with a safety closing device according to the local regulations in force.

See image 8 for a visual reference.

Refrigerator operation

- Make sure no products in your refrigerator can move while driving. Secure the bottles in the door and the drawer with the bottle retainer and drawer divider (if present). Secure all food on the storage shelves with the shelf food retainers (if present).

- Close the door

See *image 9* for a visual reference.

NOTE: When you close and press the door of the refrigerator, the door locks automatically. While driving, this door lock also secures the door. Some models have an extra security lock on the bottom of the refrigerator. To be sure the door will not open while driving, push the security lock over the pin on the door.

Winter use

See *image 10* for a visual reference.

- When you are going to use the refrigerator with an outside temperature below 6C, install a suitable winter cover, all illustrated.

NOTE: This cover will protect your refrigerator against too cold air and makes sure the refrigerator will still perform optimally.

Warning

Make sure you remove the winter cover again once the temperature is above 6°C.

Maintenance and cleaning

Warning

Before carrying out any kind of maintenance or cleaning on your refrigerator, switch off your refrigerator and disconnect both the AC and DC power sources.

It is important to regularly clean the refrigerator for optimal performance. First remove the shelves, door bins, slide-out box and the drawer. Then clean those parts and the inside of the refrigerator with a soft cloth and a mild

household cleaner. Use a wet, soft cloth for the outside of the refrigerator. Make sure the vents on the outside of the vehicle are always dust-tight.

Removing slide-out box system (model C1 and C2)

See *image 11* for a visual reference.

To remove the slide-out box system:

- Completely open the fresh food compartment door and remove the slide-out box.
- Then slide the rail system to the right, as illustrated.
- Remove and clean the slide-out box system.
- After cleaning, place the system back in reverse order.
- Make sure the slide out box system snaps into place.

Removing slide-out box system (model B)

See image 12 for a visual reference.

To remove the slide-out box system:

- Completely open the fresh food compartment door and remove the slide-out box.
- Locate the two clips at the back of the rail system (1).
- Pull the clips upwards and forwards until they are released.
- Lower the front and slide the rail system further to the front (2).
- Remove and clean the slide-out box system.
- After cleaning, place the system back in reverse order until you hear a click. For left turning door, place the system into the slots on the right-hand side.
- Make sure the system locks into place.

Removing drawer (model C1)

See image 13 for a visual reference.

To remove the drawer for refrigerator model C1:

- Pull the drawer until the stop and push it a little bit back.
- Then push the guide locks backwards, as illustrated.
- Pull the drawer further to the front and lift the wheels over the curves.
- Remove and clean the drawer.
- After cleaning, pull out the guides until they snap into place.
- Place the drawer back in reverse order.

NOTE: The loose parts of the refrigerator are not suitable for the dishwasher.

Warning

Do not use abrasive cleaners, metal scouring pads or hard brushes. They could damage the refrigerator.

Never clean the refrigerator with soap or aggressive, caustic or soda-based cleaning agents.

Water through the vents may damage your refrigerator.

Refrigerator operation

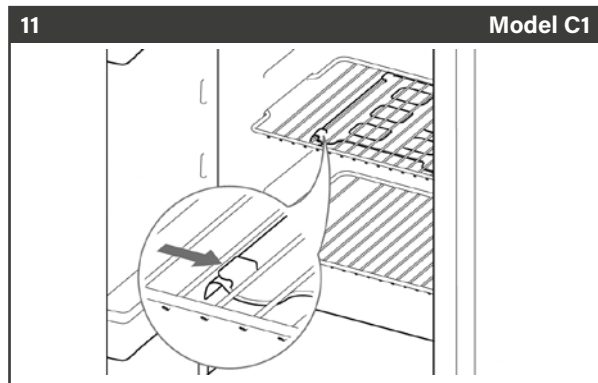
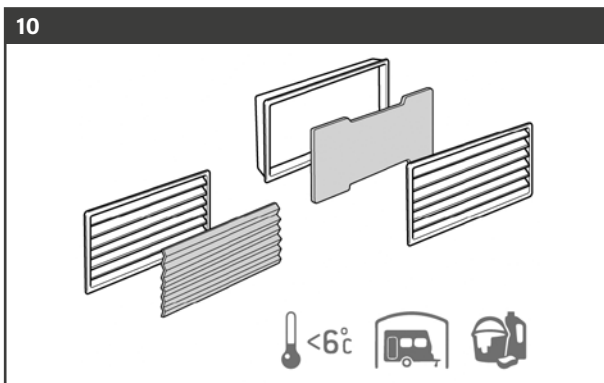
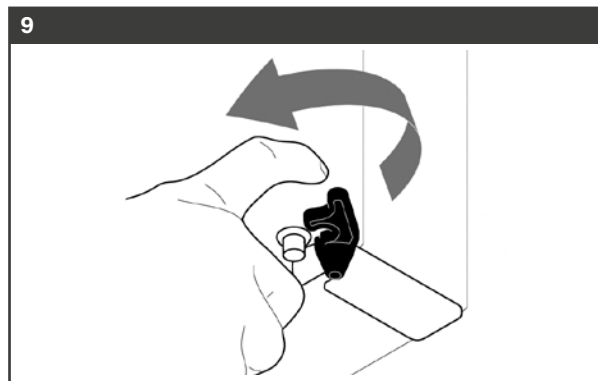
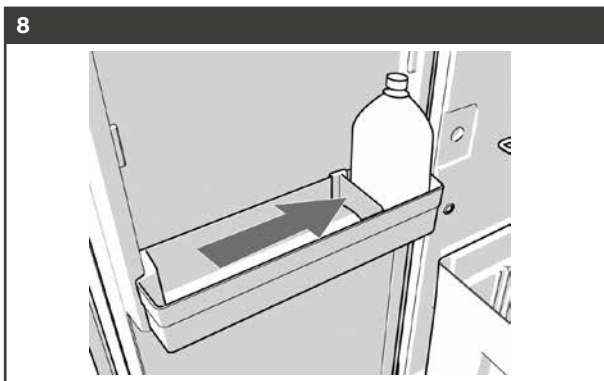

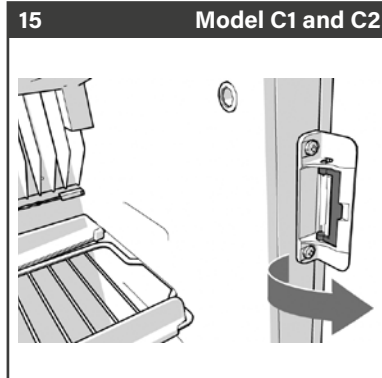
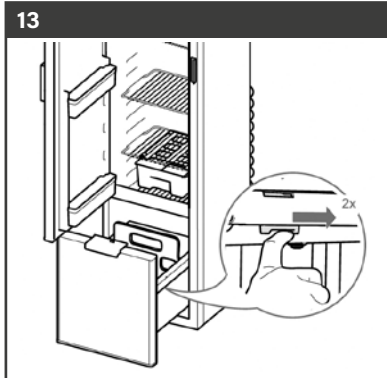
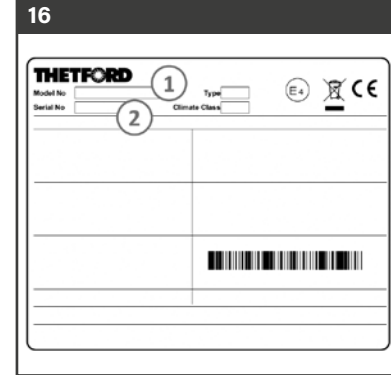
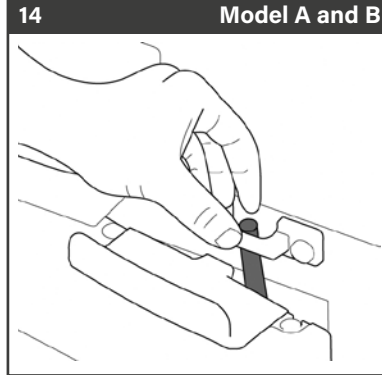
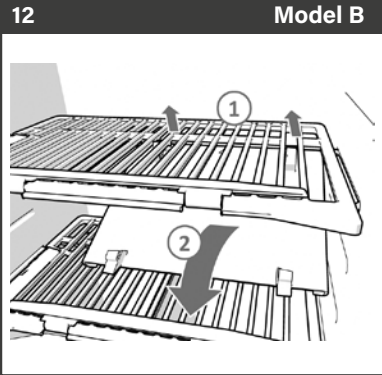

Refrigerator operation

Troubleshooting

Problem	Possible cause	Solution
Refrigerator does not start	Refrigerator is not switched on Vehicle is not level	Switch on the refrigerator Make sure the vehicle is level Try to start the refrigerator on another power source
Model with LCD display: Error codes 1, 2, 4, 5, 8, 8, 12 or 13 light up on the control panel	Multiple causes	Switch the refrigerator off and on again. If the problem still exists, contact a service centre
Error code 3 Refrigerator does not work on gas	Gas bottle is empty The valve of the gas bottle and/or the shut-off valves are closed Refrigerator is not switched on	Replace the gas bottle Open the valves Switch on the refrigerator Try to run the refrigerator on another power source
Error code 6 or 7 Refrigerator does not work on 12V	The engine is not running 12V fuse faulty	Make sure the engine is running Check if the 12V fuse in the fuse box on your vehicle is still operational Try to run the refrigerator on another power source
Error code 10 Refrigerator does not work on 230V	Mains are not available	Check if the mains is available Try to run the refrigerator on another power source



Problem	Possible cause	Solution
Error code 11 Refrigerator does not work in Auto	Sources are not connected	Connect the sources Try to run the refrigerator on another power source manually
Error code 18 All symbols light up		Wait a few seconds until the refrigerator starts normally
All lights are blinking		Switch the refrigerator off and on again. If the problems still exist, contact a service centre
Refrigerator has insufficient cooling	Ventilation openings completely or partially blocked Vehicle is not level Selected cooling level too low Fans not switched on Door is not properly closed Too much ice on cooling fins	Clean or remove blockage Make sure the vehicle is level Select a higher cooling level Switch on the fans Close the door Defrost the refrigerator If the problems still exist, contact a service centre

Refrigerator operation

Defrosting

A layer of ice on the cooling fins will decrease the cooling capacity and durability of your refrigerator. Therefore your refrigerator is provided with an automatic defrost system, which reduces ice formation.

It is also possible to defrost your refrigerator manually. To do this:

- Remove all food
- Switch off the refrigerator and open the doors
- Put a towel in the frozen food compartment and on the bottom of the fresh food compartment to catch any leakage water.

Warning

Please do not attempt to speed up the defrosting process by removing the ice layer with force or sharp objects or by using a hair-dryer or any other electrical device.

Storage

If you do not use the refrigerator for a longer period:

- Empty the refrigerator
- Defrost the frozen food compartment
- Clean the complete refrigerator thoroughly
- Install the winter cover over the vents, to protect your refrigerator during storage
- Keep the fresh food compartment door, as well as the frozen food compartment door, open during storage

To keep the door open during storage:

See image 14 for a visual reference.

- Model A and B: Rotate the storage lock and secure it by using the strike plate

See image 15 for a visual reference.

- Model C1 and C2: Rotate the storage lock.

To use the refrigerator after storage:

- Rotate the storage lock back to its original position

Warning

Make sure the gas taps of the gas bottle are closed during storage. Water through the vents may damage your refrigerator. Make sure the vent openings are covered before washing your vehicle before stalling.

Warranty and servicing

For our warranty procedure and policy, refer to www.thetford.com

All servicing must be carried out by an authorised person. Before any service work is started, the appliance must be disconnected from the electrical supplies.

For service, please contact your authorised local Service Centre giving details of the model and serial number on the Serial ID label plus date of purchase.

See *image 16* for a visual reference.

1. Model number

2. Serial number

See *images 1, 2 and 3* for position of the Serial ID label.

Safety when operating with gas

Explosion Hazard



Warning

Failure to obey these warnings could result in death or serious injury.

- Only operate the device at the pressure shown on the type plate. Only use pressure controllers with a fixed setting which comply with the national regulations.
- Never operate the device with gas:
 - At petrol stations
 - In parking garages
 - On ferries
 - While transporting the caravan or mobile home with a transport vehicle or tow truck
- Never use a naked flame to check the device for leaks.
- In case of gas odor:

- Close the gas supply lock and the valve on the cylinder.
- Open all windows and leave the room.
- Do not press an electric switch.
- Put out any naked flames.
- Have the gas system checked by a specialist.

Caravan equipment

Oven, hob and grill

Warning

The hotplate indicator will illuminate if the hotplate is hot. DO NOT shut the lid if this light is lit.

The electrical supply can be isolated by removing the 3 pin plug under the oven behind the pan flap.

Thetford Introduction

This appliance has been installed in accordance with the local, national and European regulations in force. Particular attention has been given to the requirements regarding ventilation. Read the instructions before using the appliance.

Thetfords policy is one of continuous development and improvement. Specifications and illustrations may change subsequent to publication.

Provision of Ventilation

The use of a gas cooking appliance results in the production of heat and moisture in a room in which it is installed. Ensure that the kitchen is well ventilated, keep natural ventilation holes open or install a mechanical ventilation device (mechanical extractor hood).

Prolonged intensive use of the appliance may call for additional ventilation, for example opening a window, or more effective ventilation, for example increasing the level of mechanical ventilation where present.

Warning

Shut off gas supply at isolating valve, switch off electric supply and ensure all parts are cool before cleaning or servicing.

All servicing must be carried out by an approved competent person. After each service the appliance must be checked for gas soundness. This appliance must not be modified or adjusted unless authorised and carried out by the manufacturer or his representative. No parts other than those supplied by the manufacturer should be used on this appliance. If the supply cord is damaged, it must only be replaced by the manufacturer or his representative in order to avoid a hazard.

Thetford Oven

Read the safety instructions and information on use and maintenance of the cooker carefully before continuing. This will enable you to use the cooker safely and efficiently. Retain this manual for future reference.

For the latest version of this manual, please visit www.thetford.com.

Safety

- This appliance may be used by children aged 8 years or older and persons with reduced physical, sensory or mental capabilities and/or lack of experience and knowledge only if they are supervised or have been given instructions on the safe use of this appliance and understand the potential hazards.
- Keep children younger than 8 years away from the appliance, except under constant supervision.
- Do not allow children to play with the appliance.
- Do not allow children to clean or maintain this equipment unattended.
- Use only parts supplied by the manufacturer.
- Do not change or adjust anything on the appliance, unless the change is authorised by the manufacturer or its representative.
- If the power cord is damaged, it must be replaced by the manufacturer, its service agent or similarly qualified persons in order to avoid a hazard.
- Use the appliance for cooking only and not for anything else, for example room heating. This can lead to carbon monoxide poisoning and overheating. The manufacturer cannot be held liable for damage resulting from improper use or incorrect setting of the controls.
- This appliance is not intended to be operated by means of an external timer or separate remote control system.
- The use of this gas cooking appliance results in the production of heat, moisture and products of combustion in the room in which it is installed.
- Ensure the room has sufficient ventilation when the appliance is in use. During prolonged use, additional ventilation may be needed by opening a window or increasing the extraction force of the hood.
- Never extinguish a cooking fire with water. Turn the burner off and cover the flame with a lid or a fire blanket.
- The appliance and its accessible parts become hot during use. Care should be taken to avoid touching heating elements.
- The cooking process must be supervised. A short term cooking process must be supervised continuously. Unattended cooking on a hob with fat or oil can result in fire. Do not leave the appliance unattended when in use.

Caravan equipment

- The use of inappropriate hob guards can cause accidents.
- Danger of fire, do not store items on the cooking surface of the hob.
- The food shelves and trays in the appliance are hot during and after use. Allow all parts to cool before touching them, as this can cause serious injury.
- Always use oven gloves when removing the shelves and trays.
- Do not store items in the appliance.
- Do not put heavy objects on the open appliance door.
- The appliance and accessible parts become hot when the grill is in use. Young children should be kept away.



- Caution, hot surfaces. Door must be open when grill is in use. In the event that abnormal drift in cooking

temperature of the oven is observed, have the thermostat checked by a qualified service engineer.

- Care should be taken not to overload the oven, allowing adequate spacing to ensure free circulation of heat.
- Do not use steam cleaners or pressure washers to clean the appliance. See Maintenance and cleaning for instructions.
- Do not allow oil or fat to build up on the appliance. Clean the appliance after each use.
- Before cleaning or maintenance work the appliance must be left to cool and be disconnected from the gas and electrical supplies.
- The glass lid may snap shut towards the end of lowering due to the travel-lock action of the hinges. Make sure all fingers are clear of the appliance when closing the lid.
- Do not use harsh abrasive cleaners or sharp metal scrapers to clean the

surface of the glass, since they can scratch the glass surface which may result in shattering of the glass.

- Remove any spillage from the glass lid before opening the lid.
- Do not shut the glass lid when the burners are lit or still warm.



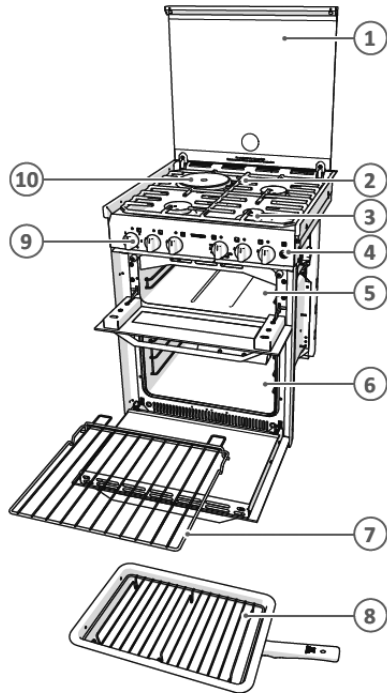

Main components

1. Glass lid
2. Pan supports
3. Gas burners
4. Spark ignition (optional)
5. Grill
6. Oven
7. Oven shelf
8. Grill pan
9. Control panel
10. Electric hotplate (Dual Fuel only)

The types of burners may vary depending on the type of appliance. Refer to Technical specifications for further details.

Before use

Before using the appliance:

- Ensure that all packaging materials have been removed.
- Clean the appliance with warm water and household detergent and dry carefully with a soft cloth.
- Ensure that the gas supply is connected and turned on.

- Ensure that the appliance is connected to the 12V DC battery for the cooling fans and spark ignition.
- Ensure that the pan supports are positioned properly.
- Ignite the gas burners and let them burn to expel odours and vapours first.
- Ignite the burner and heat the grill for about 20 minutes to eliminate any residual factory lubricants that might impart unpleasant smells to the food being cooked. Smoke may occur during this procedure. Open any windows and turn on mechanical ventilators to help remove the smoke.
- Ignite the burner and heat the oven for about 30 minutes at 200°C to eliminate any residual factory lubricants that might impart unpleasant smells to cooked food. Smoke may occur during this procedure. Open any windows and turn on mechanical ventilators to help remove the smoke.

Caravan equipment

Dual fuel only:

- Ensure the electricity is connected and switched on.
- Prime the hotplate by switching on the hotplate for a short period, without a pan, to harden and burn off the coating. Use a medium to high setting for 3 - 5 minutes. Allow adequate ventilation to disperse any smoke that occurs during this process. Allow the hotplate to cool.
- Season the hotplate by heating the hotplate for 30 seconds on a medium setting and then switching off. Pour a minimal amount of unsalted vegetable oil onto a clean dry cloth or paper towel, and apply a thin coat of oil to the hotplate surface. Wipe off any excess oil, then heat the hotplate on a medium setting for 1 minute. Occasional seasoning will help to maintain the hotplate's appearance.

Warning

Only use LPG (Liquefied Petroleum Gas). The appliance operates on propane or butane. Propane is preferred over butane, because butane provides poor performance at an ambient temperature below 10°C and cannot be used at an ambient temperature below 5°C.

Use of the burners

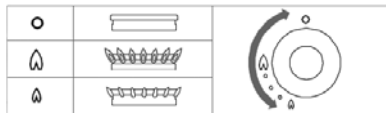

For the exact location of the control knobs, see main components. Turning on:

- Push and turn the control knob.
- Turn the control knob anti-clockwise to the full rate position.
- Push the ignition button
- Keep the control knob pressed for about 10-15 seconds and then release it.

- Adjust the height of the flame.

Warning

If the burner accidentally extinguishes turn the control knob to the 0 position and wait at least 1 minute before re-igniting the burner. If the burner has not lit within 15 seconds turn the control knob back to the 0 position and release it. Wait at least 1 minute and repeat the steps above to turn on the appliance.

Turning off:

- Turn the control knob clockwise to the 0 position to turn off the burner.

Warning

Always make sure the control knob is in the 0 position when you have finished using the gas burners. Do not shut the glass lid when the burners are lit or still warm.

Use of the electric hotplate (if applicable)

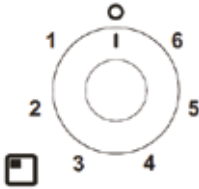

For the exact location of the control knob, see main components. Turning on:

- Rotate the control knob either clockwise or anti-clockwise to the required position (1 - 6).

Warning

For maximum efficiency, a correctly sized pan with a flat heavy gauge base should be used. The pan size should be the same or slightly larger than the hotplate (up to 1" /2.5cm oversize).

Turning off:

- Turn the control knob to the 0 position to turn off the hotplate.

Warning

Always make sure the control knob is in the off position when you have finished using the hotplate.

Do not shut the glass lid when the hotplate is turned on or still warm.



Use of the grill

For the exact location of the control knob, see main components.

Turning on:

- Open the door and push the control knob.
- Continue pressing the control knob

and turn it anti-clockwise to the full rate position.

- For spark ignition models: Push the ignition button.
- For non-ignition models: Hold a lit match or gas match to the burner.
- Keep the control knob pressed for about 10-15 seconds and then release it.
- Adjust the required heat setting.
- Depending on the food to be cooked, the correct grilling height can be achieved by inverting the pan trivet into either the high or low position.
- The grill pan supplied is multi-functional, for use in grill or oven and the handle design allows removal or insertion whilst the pan is in use. Always remove the handle when the pan is in use.

Caravan equipment

Warning

The grill door must remain open when lighting and using the grill.

If the burner accidentally extinguishes turn the control knob to the 0 position and wait at least 1 minute before re-igniting the burner.

If the burner has not lit within 15 seconds turn the control knob back to the 0 position and release it. Wait at least 1 minute and repeat the steps above to turn on the appliance. Although the grill heats up quickly, it is recommended that a few minutes preheat be allowed.

It is normal for the flames on this burner to develop yellow tips as the grill heats up.

Turning off:

- Turn the control knob clockwise to the 0 position to turn off the grill.

Warning

Always make sure the control knob is in the 0 position when you have finished using the grill.

Use of the oven

For the exact location of the control knob, see main components.

Turning on:

- Open the door and push in the control knob.
- Continue pressing the knob and turn it anti-clockwise to the full rate position (240°C, gas mark 9).
- Push the ignition button.
- Keep the control knob pressed for about 10-15 seconds and then release it.
- Adjust the required heat setting.
- Place the oven shelf in the required position and close the door.

Warning

Ignition must always be carried out with the oven door open.

If the burner accidentally extinguishes turn the control knob to the 0 position and wait at least 1 minute before re-igniting the burner.

If the burner has not lit within 15 seconds turn the control knob back to the 0 position and release it. Wait at least 1 minute and repeat the steps above to turn on the appliance. Although the oven heats up quickly, a 10 minute preheat is recommended. The oven should reach full temperature in about 15-20 minutes.

Turning off:

- Turn the control knob clockwise to the 0 position to turn off the oven.

Warning

Always make sure the control knob is in the 0 position when you have finished using the grill.

Safe cooking

- Do not allow cooking vessels to overlap the edges of the appliance - use the correct sizes of pans and position them centrally over the burners.

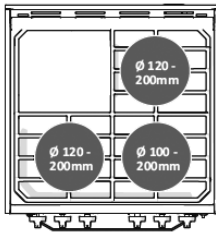

- Ensure that there is at least a 10mm gap between the pans and the edges of the hob.
- Turn the pans so that the handles do not overhang the front of the appliance.
- Ensure that the flame of the gas burner heats the bottom of the pan, not the sides.
- The pans and trays supplied with this appliance are the maximum sizes.

Do not use larger pans and trays. They may restrict good circulation of heat, which may increase cooking times.

- Do not leave the appliance unattended when in use.
- Do not use the appliance while the vehicle is moving.
- Turn the control knob back to the 0 position after cooking.
- Keep the appliance clean and prevent accumulation of grease and food scraps.

Warning

Never cover slots or holes in the appliance and never cover a shelf with materials such as aluminium foil. That restricts the airflow and may cause carbon monoxide poisoning. The food shelves and trays in the appliance are hot during and after use. Allow all parts to cool before touching them, as this can cause serious injury. Always use oven gloves when removing the shelves and trays.

Temperature control

The temperature in the oven is controlled by a thermostatic gas tap and is variable over the range 120°C to 240°C.

Warning

Care should be taken not to overload the oven, allow adequate spacing to ensure free circulation of heat. When roasting with aluminium foil ensure the foil does not impair circulation of heat or block any oven flue outlet.

Caravan equipment

Maintenance and cleaning

Thetford recommends an annual inspection service by an approved service centre. Between annual servicing, clean the appliance regularly after use. Before any cleaning work is started, the appliance should have been left to cool and be disconnected from the gas and electrical supplies.

- Always remove any spills or contamination immediately after use with soap and hot water. Towel dry the surface with a soft cloth.
- Use a non-abrasive multi-purpose cream cleaner and a nylon scourer pad to clean more stubborn dirt or grease.
- Use a proprietary stainless steel cleaner or polish to remove superficial surface scratching.

Warning

Do not use abrasive cleaners, metal scouring pads or hard brushes. They could damage the appliance.

Warning

If you clean the burner rings, ensure that the holes are not clogged.

Do not use harsh abrasive cleaners or sharp metal scrapers to clean the glass surface, since they can scratch the glass surface which may result in shattering of the glass.

Do not leave wet cloths, cleaning pads, residues of food or cleaning products or other dirt to dry on the surface. It can cause pitting, marking or even rusting. Always clean in the direction of the brushed finish and not across the grain. Cleaning agents containing bleach should not be left in contact with stainless steel.

Mineral content in water (such as iron or lime scale) can affect the appearance of the metal.

Remove any spillage from the glass lid before opening the lid.

The control knobs can be removed for cleaning. The knobs are easy to replace.

Gas leaks

As soon as you smell gas:

- Ensure that all burners are turned off.
- Extinguish all naked lights and do not smoke.
- Shut off the gas supply at the gas bottle immediately.
- Do not use electrical switches.
- Open all doors and windows.

Warning

LPG is heavier than air. Escaping gas accumulates at lower levels. By following the strong, unpleasant smell of gas, you can determine where the leak is located. To investigate where it is exactly, use a special leak detection spray. Never use an open flame to find the leak!

Troubleshooting

Problem	Possible cause	Solution
Burners do not burn or burn unevenly	Gas bottle is empty as tap is closed. Burner caps are not correctly positioned. Burners are wet or clogged.	Change gas bottle. Open tap. Allow caps to cool, then re-position them. Dry or clean burners.
Spark ignition does not spark	12V DC battery is discharged. Connections are loose. Ignition points are wet or dirty.	Charge battery. Secure connections. Dry or clean ignition points.
Control knobs do not function	Knobs are mounted incorrectly.	Install knobs correctly.

Servicing

All servicing must be carried out by an approved competent person. Before any service work is started, the appliance should have been left to cool and be disconnected from both the gas and electrical supplies. After each service the appliance must be checked for gas soundness and electrical safety.

For service, please contact your authorised local Service Centre giving details of the model and serial number on the data badge plus date of purchase.

Model Name & Series Number		Barcode	
Gas	CAT 1,+(28-30/37)	CAT 1,B/P(30)	THETFORD
031	BUTANE 28-30mbar PROPANE 37mbar	BUTANE 30mbar PROPANE 28mbar	
Qn	Power kW (gBr)	Model Number	Spark Ignition
CE	Pin Number	Serial Number	Voltage ~ 50 Hz
	Country Codes 1	Country Codes 2	Power kW
			QC Pass
			Order No.

Putting in storage

- Close the gas valve at the gas bottle.
- Dual fuel only: Disconnect the electrical supply.
- Spark ignition models only: Disconnect the battery.
- Ensure that the control knobs are in the 0 position.
- Close the glass lid.
- Close the grill door.
- Close the oven door.
- Wipe the appliance clean and dry.

Warning

This appliance is suitable for use with LPG (Liquefied Petroleum Gas) and should not be used with any other gas. This appliance must be earthed.

Caravan equipment

To reduce energy use on the hob while cooking:

- Use the correct size of pan - a pan which fits the hotplate will use less energy than one that is too large or too small.
- Use the minimum heat setting to maintain simmering or boiling - additional heat is just wasted.
- Cover pans or kettles with a lid whenever possible - this helps to retain heat.
- Do not use old, damaged or distorted pans, they will reduce efficiency.

Questions

If you have questions about your product, parts, accessories or authorised services:

- Visit www.thetford.com.
- If you cannot solve a problem, contact the authorised local Service Centre or Thetford Customer Service in your country.

Warranty

Thetford BV offers the end users of its products a three-year warranty. In the case of malfunction within the warranty period, Thetford will replace or repair the product. In this situation, the costs of replacement, labour costs for the replacement of defective components and/or the costs of the parts themselves will be paid for by Thetford.

Purchased spare parts carry a one-year warranty. Any fitting and/or labour costs are not covered by warranty.

1. To submit a claim under this warranty, the user must take the product to an authorised Thetford Service Partner. The claim will be assessed there.
2. Components replaced during repair under warranty become the property of Thetford.
3. This warranty does not prejudice current consumer protection laws.

4. This warranty is not valid in the case of products that are used for commercial purposes.

5. Warranty claims falling into one of the following categories will not be honored:

- The product has been improperly used or the instructions in the manual have not been followed;
- The product has not been installed in accordance with the instructions;
- Modifications have been made to the product;
- The product has been repaired but not by an authorised Thetford Service Partner;
- The serial number or product code has been tampered with or removed;
- The product has been damaged by misuse.



Fig no.1

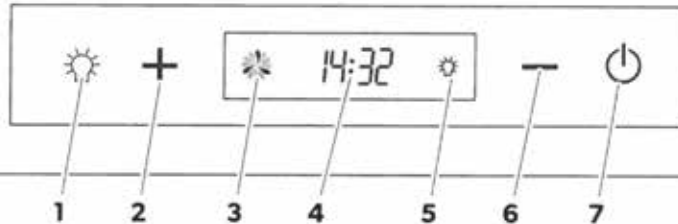

**Dometic CK500 extractor hood
(where fitted)**

Safety instructions

Please observe the prescribed safety instructions and stipulations from the vehicle manufacturer and service workshops.

The manufacturer accepts no liability for damage in the following cases:

- Faulty assembly or connection.
- Damage to the product resulting from mechanical influences and excess voltage.
- Alterations to the product without express permission from the manufacturer.
- Use for purposes other than those described in the operating manual.

Note the following basic safety information when using electrical devices to protect against:

- Electric shock
- Fire hazards
- Injury

Fig no.2

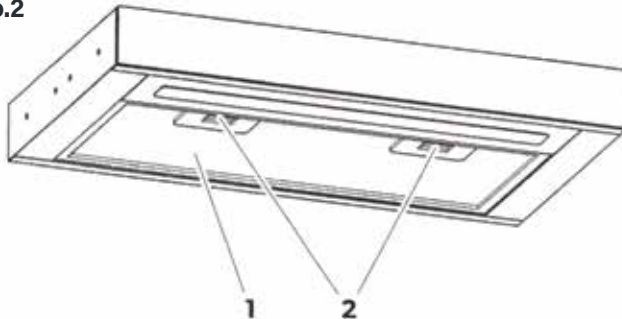

Caravan equipment





Technical description

The CK500 extractor hood removes odours and steam that occurs during cooking.

Its filter is detachable and washable.

The CK500 features an LED light, two fans and a touch display.

Control elements

No. in fig.1	Description
1	 Switches the light on and off
2	 Increases the fan speed and sets the time or the timer
3	 Displays the fan speed
4	Displays the time or the timer
5	Lights up when the light is switched on
6	 Decreases the fan speed and sets the time or the timer
7	 Switches the extractor hood on and off

Filter

No. in fig.2	Description
1	Filter
2	Lock Push to the rear: unlock and remove the filter

Operating the device

Switching the extractor hood on and off

- ▶ Press the  button to switch the extractor hood on or off.

Setting the time

NOTE:

When the extractor hood is connected to the power supply, the display shows .

After three seconds without any entries, the settings are saved.

- ▶ Switch on the extractor hood.

- ▶ Press the  button for three seconds to set the hours.

✓ A confirmation signal is emitted.

✓ All the digits on the clock flash.

- ▶ Set the hours with the  or  button.

- ▶ Press the  button for three seconds to set the minutes.

✓ A confirmation signal is emitted.

✓ All the digits on the clock flash.

- ▶ Set the minutes with the  or  button.

- ▶ Wait three seconds.

✓ The digits on the clock light up permanently.

✓ The new time setting is saved.



NOTE:

In the time between 8 pm and 6 am, the display on the clock disappears after 5 minutes if none of the buttons have been pressed.





Switching the light on and off



- Press the  button to switch the light on and off.

Setting the fan speed

- Press the  button to increase the fan speed.
- Press the  button to decrease the fan speed.

Setting the timer

- Switch on the extractor hood.
- Press the  and  buttons simultaneously to set the timer.
- ✓ A confirmation signal is emitted.
- ✓ All digits on the timer flash.
- Set the seconds with the  or  buttons.
- Press the  button for three seconds to set the minutes.
- ✓ A confirmation signal is emitted.
- ✓ All digits on the timer flash.

- Set the clock with the  buttons or  the minutes.

NOTE:

Maximum recordable time is **99:00** minutes.

- Wait three seconds.
- ✓ The digits on the timer light up permanently.
- ✓ The timer counts down.
- ✓ After the time has elapsed, the confirmation signal sounds several times.

Cleaning

NOTICE!

- Do **not** use sharp or hard objects or cleaning agents for cleaning as these may damage the product.
- Do **not** clean the electronic components of the extractor hood with water or a wet cloth.

NOTE:

- The filter of the extractor hood must be cleaned regularly, as grease collects there. How often cleaning is necessary depends on how often you cook and how often the extractor hood is switched on.
- Clean the filter before the performance of the extractor hood noticeably declines.
- The filter can be replaced. Please contact the manufacturer's branch in your country (see the back of the instruction manual for the addresses) or your retailer.

- Switch off the extractor hood.
- Occasionally clean the product with a damp cloth and a synthetic detergent (such as washing-up liquid).
- Remove the filter and clean it with warm water and a synthetic detergent (such as washing-up liquid).

Caravan equipment

- Leave the filter to dry before you replace it.

Warranty

The statutory warranty period applies. If the product is defective, please contact the manufacturer's branch in your country (see the back of the instruction manual for the addresses) or your retailer.

For repair and guarantee processing, please include the following documents when you send in the device:

- A copy of the receipt with purchasing date.
- A reason for the claim or description of the fault.

Technical data

	CK500
Ref. no.:	9106506287
Voltage:	12 V
Capacity:	100 m ³ /h
Power consumption:	35 W
Light intensity:	3 W
Dimensions (W x H x D):	530 x 60 x 204 mm
Weight:	2.5 kg
Test mark:	



Microwave oven

All our caravans are fitted with a microwave oven, for usage instructions please refer to the Manufacturers Operation Manual and Cookbook. We would however draw your attention to the following important safety instruction and information.

Important safety instructions

Please read carefully and keep for future reference.

Microwave Oven Use:

- The oven is for domestic food use only.
- Never operate the oven when empty.
- Do not leave or store anything inside the oven when not in use.
- Never attempt to use the oven with the door open. It is important not to force or tamper with the door safety latches.
- Never operate the oven with any object caught in the door.

- Do not insert fingers or objects in the holes of the door latches or air-vent openings as this may damage the oven and cause an electric shock.
- If water or food drops inside the air vent openings switch off the oven immediately, unplug it and call an approved service facility.

Warning

Never allow children to use the microwave oven without adult supervision.

Warning

Liquids and other foods must not be heated in sealed containers since they are liable to explode. Microwave heating of beverages can result in delayed eruptive boiling, therefore care has to be taken when handling the container. Stir the liquid prior to and during heating/reheating, let liquid stand for at least 20 seconds in the oven after cooking.

Warning

If smoke is observed, switch off and unplug the appliance and keep the door closed in order to stifle any flames.

How your microwave oven works

Microwaves are energy waves, similar to those used for TV and radio signals.

Electrical energy is converted into microwave energy, which is directed into the oven cavity via a waveguide. To prevent food and grease entering the waveguide it is protected by the waveguide cover.

Microwaves cannot pass through metal, because of this the oven cavity is made of metal and there is a fine metal mesh on the door. During cooking the microwaves bounce off the sides of the oven cavity at random.

Caravan equipment

Microwaves will pass through certain materials, such as glass and plastic, to heat the food.

Water, sugar and fat in food absorb microwaves which cause them to vibrate. This creates heat by friction, in the same way your hands get warm when you rub them together.

Once cooking is complete the oven automatically stops producing microwaves.

Standing time is necessary after cooking, as it enables the heat to disperse equally throughout the food.

Warning

Microwaves are not designed to run continuously for over 20 minutes. If in hot conditions the microwave stops, then it may have tripped into a thermal overload condition. Allow the microwave to cool down and then reset if required.

Smoke alarm

The smoke alarm fitted to your caravan is approved for use in caravans and motor homes. The National Caravan Council (NCC) requires that all new or used touring caravans sold by its members be fitted with a smoke alarm featuring an alarm silence facility.

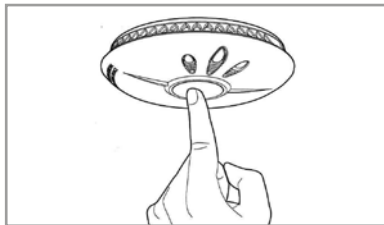

WARNING

Test smoke alarm operation after your caravan has been in storage, before each trip and at least once per week during use.

Warning

A different smoke alarm to the one illustrated may be fitted (subject to availability) but it still meets the criteria above.

For further information on use of the alarm, battery replacement, testing etc., refer to the manufacturer's literature contained in the Owner's Information Pack.

Operating Features

- An advanced electrochemical sensor designed to accurately measure low levels of carbon monoxide (CO) providing an early warning of toxic CO levels in your home.
- Detects carbon monoxide continuously.
- Resistant to false alarms caused by normal household contaminants.
- Sounds a loud 85dB alarm (at 1 meter (3 feet)) to alert you in case of an emergency.

- Test/reset button.
- Regular self-check to ensure detector is operating correctly.
- Simple to mount, portable, ideal for travelling.
- Independently tested to confirm to the European Carbon Monoxide Alarm Standard BS EN 50291 : 2001.

Carbon Monoxide and how it can affect you and your family.

Carbon monoxide is a dangerous, poisonous gas that kills hundreds of people each year and injures many more. It is often referred to as the silent killer because it has no odour or taste and cannot be seen.

Like oxygen, CO enters the body through the lungs during the normal breathing process. It competes with oxygen by replacing it in the red blood cells, thereby reducing the flow of oxygen to the heart, brain and other vital organs. In high concentrations CO can kill in minutes.

Many cases of reported carbon monoxide poisoning indicate that while victims are aware they are not feeling well, they become disorientated and unable to save themselves by either exiting the building or calling for assistance. Exposure during sleep is particularly dangerous because the victim usually does not wake up.

Symptoms of CO poisoning

The following symptoms may be related to CO poisoning which all household members should be made aware of:

- Mild Exposure: Slight headache, nausea, vomiting, fatigue (often described as 'flu-like' symptoms).
- Medium Exposure: Severe throbbing headache, drowsiness, confusion, fast heart rate.
- Extreme Exposure: Unconsciousness, convulsions, cardiorespiratory failure.

Your detector monitors the level of CO as parts per million (ppm) in the atmosphere surrounding the detector.

Caravan equipment

35ppm The maximum allowable concentration for continuous exposure for healthy adults in any 8 hour period, as recommended by the Occupational Safety and Health Administration (OSHA).

200ppm Slight headache, fatigue, dizziness, nausea after 2-3 hours.

400ppm Frontal headaches within 1-2 hours, life threatening after 3 hours.

800ppm Dizziness, nausea and convulsions within 45 minutes. Unconsciousness within 2 hours. Death within 2-3 hours.

Should you suspect CO may be affecting you and your family, open the doors and windows of your caravan to ventilate, turn off your appliances and evacuate the caravan. Medical attention should be sought for anyone suffering the effects of CO poisoning.

Common sources of CO

- Oil and gas boilers
- Portable generators
- Oil or solid fuel cookers
- Gas or paraffin heaters
- Barbecues
- Clogged chimneys
- Wood or gas fireplaces
- Cigarette smoke
- Gas appliances
- Any fossil fuel burning appliance

Warning

This carbon monoxide detector is not a combustible gas detector, nor a smoke detector. Do not use this carbon monoxide detector on an intermittent basis, or as a portable detector for trying to trace one source of the spillage of combustion products from fuelburning appliances or from chimneys.

Warning

DO NOT:

- IGNORE ANY WARNING FROM YOUR CO DETECTOR!
- Burn charcoal inside your home, caravan, tent or cabin.
- Install, convert or service fuelburning appliances without proper knowledge, skill and expertise.
- Use a gas cooker for heating a room.
- Operate unvented gas burning appliances using paraffin or natural gas in closed rooms.
- Operate petrol-powered engines indoors or in confined areas.
- Barbecue indoors, or in an attached garage.
- Ignore a safety device when it shuts an appliance off.

ALWAYS

- Install appliances according to the manufacturer's instructions.



- Have appliance installations carried out by professionals (for gas appliances engineers should be registered on the Gas Safe register).
- Have your appliances checked regularly by a qualified service engineer.
- Make regular visual inspections of all fuel-burning appliances.
- Only install CO detectors that meet the requirements of BS EN 50291:2001 in your home.
- Be aware of CO poisoning symptoms.

EDUCATE YOURSELF AND YOUR FAMILY ON THE SOURCES AND SYMPTOMS OF CO POISONING AND HOW TO USE YOUR CARBON MONOXIDE DETECTOR.

Power pack activation

- a.** Your detector comes complete with an integrated power pack that will provide power for its entire operational life. To activate the power pack you need to pull the disabling tab. This

will in turn pull out the metal disabling clip, which is attached to the end of the tab, from the disabling socket which is situated on the underside of the detector. Retain the disabling tab for future use.

- b.** When the detector is activated the Power LED will begin to flash once every minute to indicate that the detector is receiving power from the power pack and is fully operational.
- c.** Test the sounder, power pack and circuitry by pressing and holding the centre of the Test/Reset button briefly to confirm that the detector is operating properly. The sounder will sound as soon as the button is pressed and the Alarm LED will illuminate red indicating that the sounder is working and the power pack is providing power to the unit. This test for the sounder, power pack and circuitry should be performed on a weekly basis. This should be continued for the lifetime of the product.

⚠ Warning

Prolonged exposure to the sounder in close proximity to your ears may damage your hearing. Under normal operating conditions, the power pack will last for the lifetime of the product.

The detector will not protect against the risk of carbon monoxide poisoning when the power pack has drained.

Caravan equipment

Warning

Constant exposure to extreme high or low temperatures may reduce the life of the power pack.

Carbon Monoxide poisonous gas alarm

Test/Reset button feature

This button will:

- Test the sounder, power pack and circuitry.
- Allows you to test the sensor by introducing a source of CO into the detector (See 'Testing the Sensor' below).
- Silence the loud 85dB (at 1 meter (3 feet)) sounder during an alarm (only for alarms due to levels of CO of less than 50ppm).

Testing the sounder, power pack and circuitry

Test the sounder, power pack and circuitry by pressing and releasing the Test/Reset button to confirm that the detector is

operating properly. The sounder should sound as soon as the button is pressed, and the Alarm LED will illuminate red indicating that the sounder is working and the power pack is providing power to the unit. This test for the sounder, battery and circuitry should be performed on a weekly basis.

Understanding the product's indicator

The higher the concentration of carbon monoxide detected by the detector, the quicker it will respond. When sufficient carbon monoxide is detected a loud audible signal *8.5 dB at 1m (3 feet) will be emitted and the Alarm LED will flash red **once every second**.

The Alarm will sound:

- Between 60 and 90 minutes when exposed to 50ppm of CO.
- Between 10 and 40 minutes when exposed to 100ppm of CO.
- Within 3 minutes when exposed to

300ppm or more of CO.

Fault/low power pack signal:

The unit continuously checks the settings of its sensor and circuitry. If any of these settings are found to be incorrect or if the power pack becomes low then the detector will emit a single chirp once per minute and the Fault LED will flash once per minute for up to 30 days.



Maintaining/testing your detector

Maintenance

Your detector will alert you to potentially hazardous CO concentrations in your caravan when maintained properly. To maintain your detector in proper working order, and to ensure that the sensor will last for the lifetime of the product, it is recommended that you:

- Test the sounder, power pack and circuitry of your detector at least once per week by pressing the Test/Reset button briefly.
- Perform the Sensor Test once every month.
- Keep the detector free of dust by gently vacuuming the case with a soft brush attachment once per month.

To prevent the possibility of contaminating the sensor in your detector and thus affecting its reliability:

- Never use cleaning solutions on your

detector. Simply wipe with a slightly damp cloth.

- Do not paint the detector.
- Do not spray aerosols on or near the detector.
- Do not use any solvent based products near the detector.
- Move the detector to a safe location and store in a plastic bag before performing any activities using substances that emit strong fumes. Remember to remove it from the bag and replace the detector when these activities are finished.

What to do in the event of an alarm

WARNING

A loud alarm is a warning that unusually high and potentially lethal levels of carbon monoxide are present. Never ignore this alarm, further exposure can be fatal. Immediately check residents for symptoms of carbon monoxide poisoning, and

contact the proper authorities to resolve all CO problems. **NEVER IGNORE ANY ALARM.**

Please carefully review the owner's manual to ensure that you know what actions to take in the event of an alarm.

What to do during an alarm

- Keep calm and open the doors and windows to ventilate the caravan.
- Turn off appliances where possible and stop using the appliances.
- Evacuate the caravan leaving the doors and windows open.
- Do not re-enter the property until the alarm has stopped. When exposed to fresh air it can take up to 10 minutes for the sensor to clear and the alarm to stop depending on the level of carbon monoxide detected.
- Get medical help immediately for anyone suffering the effects of carbon monoxide poisoning (headache, nausea), and advice that carbon monoxide poisoning

Caravan equipment

is suspected.

- Do not use the appliance again until it has been checked by an expert. In the case of gas appliances the engineer must be registered on the Gas Safe register.

Toilet Instructions

Before you put the toilet in operation please read the entire manufacturer's operating manual carefully. These manuals provide you with the necessary information for the proper use, care and servicing of the toilet.

Please ensure you observe all safety instructions.

Thetford

See Thetford quick guide supplied.

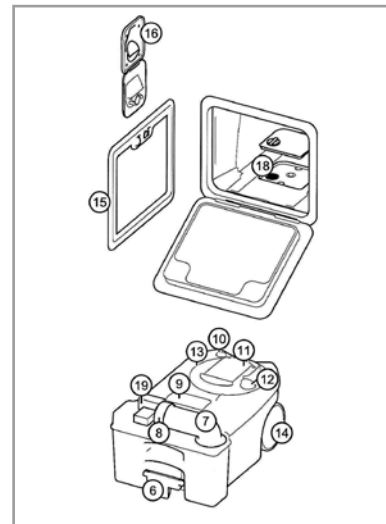
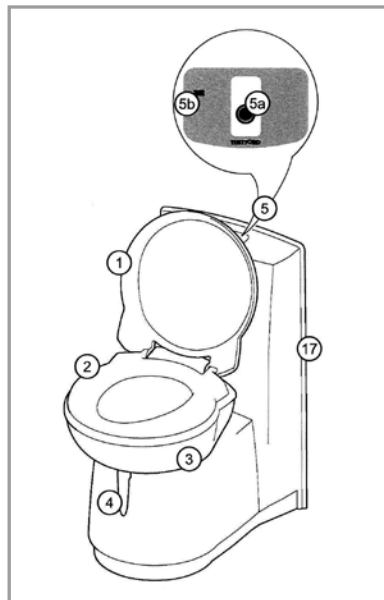

Main Parts

Standard

1. Cover.
2. Seat.
3. Swivelling toilet bowl.
4. Blade handle to open/close blade.
5. Control panel (position is different from C263 models).
- 5a. Flush button.
- 5b. Waste-holding tank level indication.
6. Waste-holding tank.
7. Waste-holding tank lid.
8. Waste-holding tank handle.
9. Waste-holding tank lock.
10. Waste-holding tank latch.
11. Waste-holding tank hinge.
12. Waste-holding tank seal.
13. Waste-holding tank gasket.
14. Waste-holding tank feet.
15. Waste-holding tank cover.
16. Waste-holding tank lid.
17. Waste-holding tank handle.
18. Waste-holding tank lock.
19. Waste-holding tank latch.

(1 level or 3 levels dependent on model).
 6. Pull handle. 7. Pour out spout. 8. Cap with measuring cup. 9. Automatic pressure release vent. 10. Vent button. 11. Sliding cover. 12. Blade opener. 13. Waste holding tank mechanism. 14. Wheel. 15. Service door. 16. Waterfill door (only for C262 model).

Introduction

This Thetford cassette toilet is a high quality product. It is user friendly, meets high quality standards and gives you all the convenience of home.

For the latest version of the manual please visit www.thetford.eu

Preparing for use

This cassette toilet has a waste holding tank of 17.5LA C262 model has its own 8L flush-water tank. Before using your toilet, it is vital that you add toilet additives to these tanks. Check the correct dosage on the additive package. Then add ± 3 L of water to the waste holding tank. Fill the flush-water tank of a C262 model to the top.

Warning

Never add toilet additives directly via the blade as this could damage the lip seal of the waste-holding tank. Add fluid via the pour out spout.

Warning

Never force if you cannot get the waste-holding tank back into place easily. If blockage occurs, always check if the blade handle is in the closed position.

Thetford offers a pleasantly scented toilet flush for the flush-water tank (Aqua rinse) and a variety of waste holding products (Aqua Kem Blue, Aqua Kem Green, Aqua Kem Natural, Aqua Kem Sachets).

Aqua rinse keeps the flush water fresh, ensures a smooth flush and leaves a protective layer. All products for the waste-holding tank suppress unpleasant smells, stimulate the breakdown of waste, reduce the formation of gas, protect moving parts and help to keep the waste-holding tank fresh and clean. For the differences

between distinguishing qualities of each waste holding tank product please visit

www.thetford.europe.com

The range of toilet products may vary for each country.

Use of your toilet

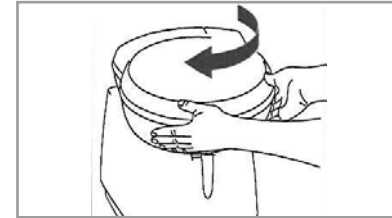

Turning the bowl

You can turn this bowl to a desired position (max ± 90). Close the cover and use both hands to rotate the bowl as illustrated.

Opening the blade

The toilet can be used with the blade open or closed. To open the blade, slide the blade handle sideways as illustrated.

Caravan equipment

Make sure you always close the blade completely after use.



Flushing the toilet

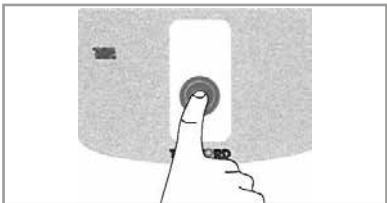

Warning

Ordinary toilet paper can cause clogging. Use Aqua Soft toilet paper instead. This toilet paper is super-soft, dissolves quickly, prevents clogging and makes it easier to empty the waste holding tank.

Press the flush button once to activate the control panel. Then press the flush button for several seconds to flush the toilet.

Level Indication

You can check whether your waste holding tank has a 1 level or a 3 level indication. Make sure the tank is empty and place it back properly. This activates the control panel. If no level indication light lights up, your toilet has a 1 level indication. It will only indicate a full tank. If a green level indication light immediately lights up, your toilet has a 3-level indication. It will show empty half full and full.

Emptying Tank Waste-Holding Tank

When the red light to the level indicator on the control panel lights up, you need to remove and empty the waste-holding tank. Remove the tank via the service door. Then take it to an authorised waste disposal point. Empty the waste holding tank via the pour out spout.

to empty the tank without splashing, press and hold the vent button with your thumb while the pour out spout is pointing downwards.

If you want to continue using your toilet after emptying, prepare the waste-holding tank gain.

Aqua Kem Green, Aqua Kem Natural and Aqua Rinse (Test ISO-11734) are absolutely safe to empty into a septic tank or small biological systems on camping sites.



Please avoid traveling with anything in the waste tank.

Flush Water Tank

The flush water tank has a capacity of 8L. Only empty the flush water tank completely if you don't expect to use your toilet for a long time (winter) period.

Place a sufficiently large bowl under the drain tube and catch the remaining water. Empty this bowl at an authorised waste disposal point.

See Thetford quick guide diagrams for visual reference.

Warning

To prevent water damage to your caravan, ensure that you don't travel with a full flush water tank, or with water in the bowl.

Cleaning

Just like your toilet at home, it is also important to clean this cassette toilet regularly. You will prevent limescale and ensure optimal hygiene. Clean the inside of the bowl with Thetford toilet bowl cleaner and a soft brush and use bathroom cleaner for the outside of the toilet.

Warning

Never use household cleaners to clean your toilet. These may cause permanent damage to the seals and other toilet components.

Remove Seat and Cover

To clean your toilet thoroughly, remove the seat and cover. First push the seat and cover together to the right, then lift them up.

Winter Use

You can use your toilet as normal in cold weather as long as the toilet is situated in a heated location. If this is not the case and there is a risk of frost, we advise not to use your toilet. Make sure you completely empty the waste-holding tank. For a C262 model also empty the flush-water tank.

Aqua Kem Sachets are particularly suitable for winter camping as the sachets are filled with powder. They completely dissolve in water, are easy to dose and economical in use.

Maintenance

To prolong the life of your toilet, maintain your toilet regularly. Use cassette tank cleaner 2 or 3 times a year on the waste-holding tank. It safely removes stubborn limescale on the inside of the tank.

When seals become dry, use seal lubricant to keep the seals soft and pliable. It has been specially developed for mobile toilets and is absolutely safe to use.

Warning

Never use Vaseline or vegetable oil to lubricate the seals as this may cause leakage to your waste-holding tank.

Storage

If you don't expect to use your toilet for a long period, you have to thoroughly empty, clean and dry the whole toilet.

Also empty the flush-water tank of a C262 model. This is also a good moment to maintain your toilet.

During storage we advise leaving the blade open to loosen the cap of the pour out spout to ventilate the waste holding tank.

Questions

If you require further information or have any questions about your toilet, please visit: www.thetford.europe.com

Caravan equipment

Spare Parts

Original Thetford spare parts are available through your own dealer or an authorised Thetford Service Centre.

FAQ

What should I do in case of a defect on my Thetford toilet?

Contact your dealer where you bought your caravan or, if you are on holiday, contact an authorised Thetford Service Centre.

A red light on the control panel flashes, what should I do?

Check if the waste-holding tank is present or positioned properly.

I cannot move the waste-holding tank.

Check if the blade of your toilet is completely closed.

What should I do when the electric blade doesn't function?

Manually open or close the blade by sliding the small handle under the toilet

bowl sideways.

What should I do if the blade is blocked?

Loosen the cap with measuring cup from the pour out spout and try again.

Does the toilet have a fuse?

Yes, the toilet has a maintenance-free self-resetting fuse.

Warranty

Thetford BV offers the end users of its products a three-year guarantee. In case of malfunction within the warranty period, Thetford will replace or repair the product at its discretion. In this case, the cost of replacement, labour costs for the replacement of defective parts and/or the costs of the parts themselves will be paid by Thetford.

1. To make a claim under this guarantee the user must take the product to his Dealer or authorised Thetford Service Centre (www.thetford.eu). The claim will be assessed there.
2. Components replaced during repair

under guarantee become the property of Thetford.

3. This warranty does not prejudice current consumer protection laws.

4. This warranty is not valid in the case of products that are for, or are used for, commercial purposes.

Guarantee claims falling into one of the following categories will not be accepted.

- The product has been improperly used or the instructions in the manual have not been followed (for example incorrect use of additives).
- The product has not been installed in accordance with the instructions.
- Alterations have been made to the product.
- The product has been repaired by an unauthorised Thetford Service Centre.
- The product code or serial ID has been changed.
- The product has been damaged by

circumstances outside the normal use of the product.

- Not using Thetford products to care for your Thetford toilet could create some damage, which would not be covered by this warranty.

Thetford is not liable for any loss and/or damage caused directly or indirectly by use of the toilet.

Roof lights

When opening the roof lights, care must be taken to release the locking mechanism as the unit is raised.

Roof lights must be fully closed when towing or in high winds.

When closed roof lights still provide fixed ventilation. Ventilation shouldn't be blocked.

Windows

All opening windows have two catch positions. The first position is for ventilation the second seals the window from ventilation and rain.

NOTE: Always have the catch in the fully closed position before travelling.

The Omnivent 12 Volt Rooflight Fan

Use of the roof light

- Close the lid before driving.
- To take away the roller blind, unscrew and click the frame off at the side of the knob.

Use of the ventilator

- The ventilator is started by the soft switch S2. The middle LED light lights up and the ventilator starts in comfort mode, this is the lowest speed (extract). See Fig 1.
- By pushing on the switch S1 (extract) or S3 (intake), the airflow can be adjusted in 6 steps.

*MIN = 3,7 /min. (2W - 0,17 A)

*MAX = 24 m3 /min. (86w - 7,20 A)

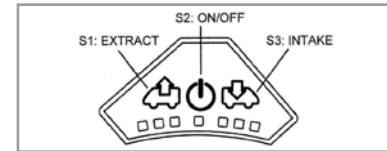

Fig.1

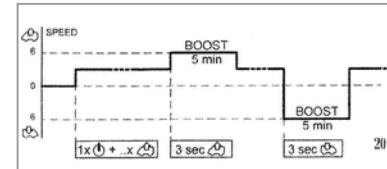

Fig.2

TROUBLE SHOOTING	
FLASHING LED's	PROBLEM
■ ■ ■ ■ ■ ■	or Tension < 11,1 V or Tension > 19,5V
■ ■ ■ ■ ■ ■	Motor blocked
■ ■ ■ ■ ■ ■	Motor not connected

Fig.3

- In order to save the battery, the speed drops from position 6 to the lowest position after one hour of use.

- It is possible to allow the ventilator to work for 5 minutes on the highest speed.

Caravan equipment

(boost). To do this push for 3 seconds on the button S1 (extraction) or S2 (intake). After 5 minutes the ventilator returns to its previous speed setting. See table in Fig. 2.

- For reasons of security, the ventilator stops when the tension is too high (19,5V), or too low (11,1V), or when the fan is blocked. For troubleshooting see Fig. 3.

Maintenance

The ventilator grid can be removed for cleaning. Also the mosquito screens can be taken out for cleaning.

The roof light is only waterproof in the direction of the traffic. When transporting the caravan in the opposite direction or when the back of the caravan is up, ensure the dome is watertight by using the 'Lock-Unlock' (not supplied on a ventilator version) or by using something that ensures that the dome remains closed when being transported.

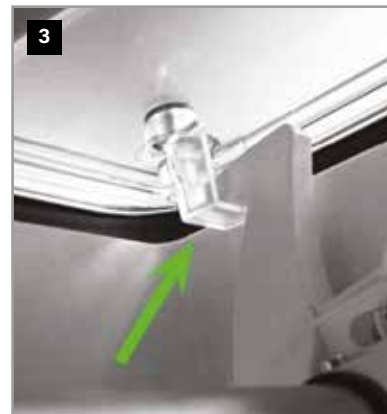
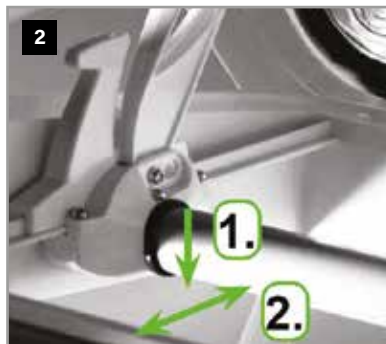
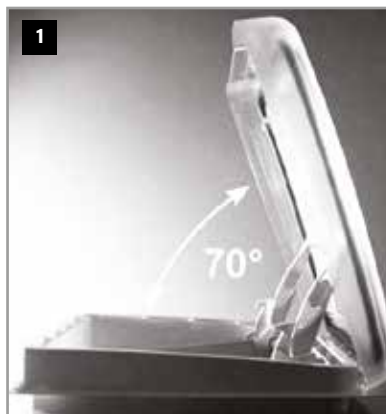

MPK VisionStar L and M pro (where fitted)

Operation instruction

Instructions for use

The rooflight can be raised to an opening angle, on one side, to a maximum of 70° (see picture 1). To open pull the operating bar down unlocking the mechanism. Now move the bar forwards (in direction of travel) and the rooflight will open; all the

time holding the bar down. As soon as the operating bar is released it will lock into position and the dome will stay at this angle. (see picture 2).

To close the rooflight, pull the operating bar down, unlocking the mechanism. Now, move the bar backwards (against the direction of travel) and the rooflight will close; all the time holding the bar down. Once you reach the end position the hooks will lock the rooflight automatically. Release the operating bar and the rooflight will remain closed. (see picture 3).

The flynet and the pleated blind can be operated together or separately. To open the rooflight dome both have to be opened.

Warning

To avoid heat accumulation do not close blind completely during the day. Open both pleats when not using the vehicle.

Before driving

IMPORTANT:

All rooflights must be locked down before traveling. Make sure the flynet and the blind are in open position to avoid damage and noise by airflow.

Care Instructions

Cleaning

Warning

The rooflight should only be cleaned by hand, using a soft cloth and plenty of clear water. To avoid scratching Caustec detergents and solvents may attack the plastic and make it brittle or disintegrate.

Micro, Midi + Mini Heki rooflight (where fitted)

Safety precautions:

1. Repairs should be carried out only by trained personnel.

2. Inform an approved dealer in case of defects and malfunctions.

3. Before starting off, check the rooflight for damage in the dome (tension cracks) and the opening mechanism which could arise owing to, for example, branches and other natural causes.

4. Do not step on the dome.

5. Close the rooflight before starting off (check whether it is locked).

6. Do not leave the vehicle with the rooflight open (danger of burglary).

7. Do not open in strong wind or rain.

8. Before opening, remove snow, ice, dirt, etc from the dome.

9. Malfunctions are to be repaired by an approved dealer at once.

10. Do not use caustic detergents (danger of tension cracks in the dome).

11. Before setting off close the dome, check the locking mechanism and open the blinds.

Caravan equipment

Care Instructions

- Clean the dome with the Seitz acrylic cleaner.
- Opaque spots and light scratches on the dome can be removed with the Seitz acrylic polish and the Seitz special polishing cloth.
- Use talcum powder regularly (four times yearly) to care for the rubber seals supplied with versions without permanent ventilation.
- Clean the blinds only with water and mild suds.

The guarantee becomes null and void if the care and safety instructions are not followed.

Micro, Midi + Mini Heki rooflight (where fitted)

Intermediate position of dome

By pushing the bar into the marked rest position, two extra opening angles, apart from the one in which the dome is fully opened, can be chosen.

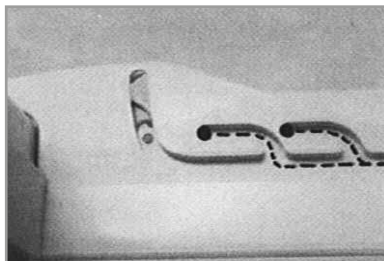

Closing the dome (Drive and rest position)

Push the bar with hands on the right and the left side in such a way that the hook bolts (1) the dome on the left and the right side and the bar lies on the push button (2). Check if the dome is locked.

Opening/closing the blind and fly net

Pull the end rod from the recessed part and push it in a position you desire. (Both systems are adjustable in any positions and can be used independently from each other).

Opening/closing the dome

Pressing the push (1) and simultaneously

open the dome with the bar (2).

Position "A"

- Push the bar (2) to the marked rest position. (●)
- Fix the bar in the rest position by pushing the sliders (3), left and right, downwards.

Position "B"

- Push the bar (2) to the marked position (●) and lead over the locking mechanism left and right by applying slight pressure.

Position "C"

- Push the bar (2) to the marked rest position (●).
- Applying slight pressure, lead the bar (2) over the catch hook (4) left and right so that the dome is locked and the bar (2) lies on the push button (1).

Position "D"

- Push the bar (2) to the marked position. (●).

Opening/closing the blind and fly net

- Push the blind (5) in the direction of the arrow (A) and the flyscreen (6) in the direction of the arrow (B).

The guarantee becomes null and void if the care and safety instructions are not followed.

Window Blinds

Pull blinds down by its centre catch. Do not pull down by one side of the blind. This will inevitably lead to problems. Do not allow blinds to spring back freely. Always control them by hand.

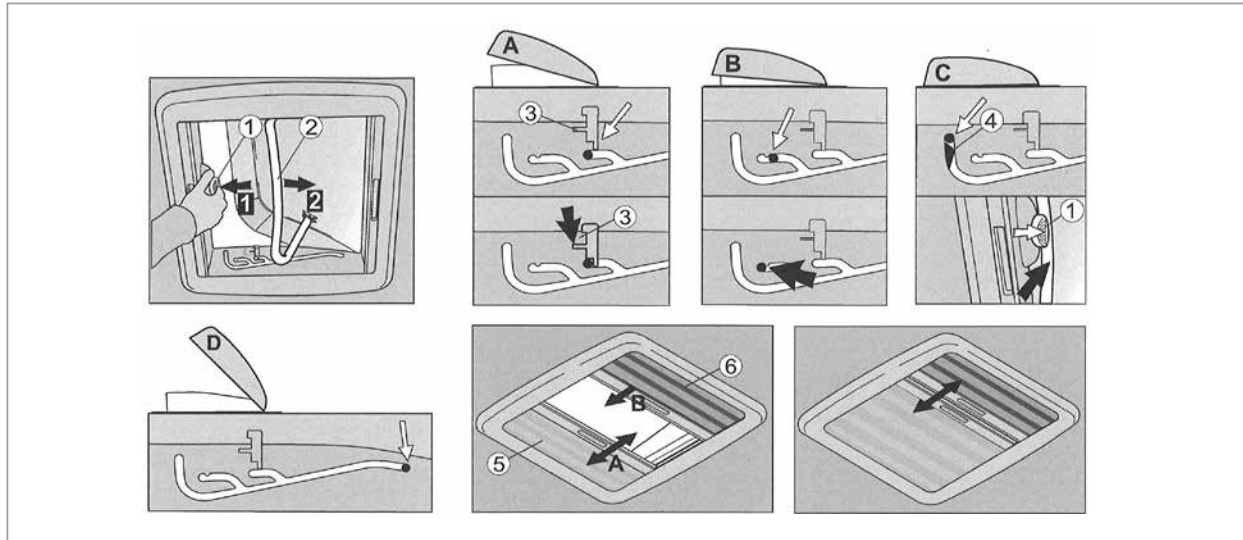

Caravan equipment

Front panoramic window blind

The blind needs to be opened and closed using two hands, one placed near to each end, to pull the blind down, or push it up. Failure to do this may lead to damage of the blind pleats, or the tensioning system.

Flyscreens

To operate the flyscreen, either pull the screen fully down or fully up, dependant on type of window fitted. To release - if a cross bar is fitted, gently pull the cross bar downwards towards you and allow the tension of the spring to roll up the flyscreen.

Where a cross bar is not fitted, disconnect from the blind catch and release gently.

It is recommended that blinds are in the open position whilst the caravan is moving.

Winterisation

Warning

DO NOT leave blinds/flyscreens in the closed position throughout the winter as the memory of the mechanism may be lost.

DO NOT leave blinds in the closed position for long periods of time in prolonged heat.

DO NOT leave blinds in the closed position during any period in storage as this can lead to heat build-up and deformation of the windows.

Gas barbecue point (where fitted)

The gas barbecue point, is situated on the nearside towards the front. This point is for use with a gas barbecue only.

Warning

This is to be used only as a gas outlet. Do not use this outlet as a means to input gas into the vehicle. Do not use a gas barbecue in an enclosed awning space.

Simply lift up the flap, unplug the red plastic end cap and connect the appliance in accordance with the gas barbecue manufacturer's instructions. Turn the gas supply valve on.

NOTE: The connection cannot be undone unless the gas supply valve is first turned off.

CAUTION! Do not use a gas barbecue inside the awning. **ALWAYS** use the appliance in the open air.

C-Line wireless speaker operation

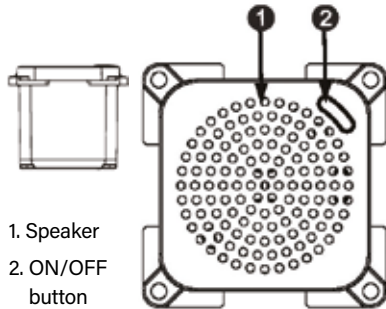

automatically when you turn them both on.

2. Turn on your device and activate the Bluetooth function.
3. Search for Bluetooth pairing name "C-line Speaker" and click to pair, the speaker will pair automatically and the speaker will have a voice prompt. Then you can play music or just need to press "⏸" button to pause the music.
4. Long press "⏸" button to turn off the speaker.

Bluetooth pairing for music

1. a. Turn on the speaker by pressing "⏸" button for 3 seconds. The speaker will have a voice prompt.
- b. Stereo mode (only for two speakers):
Power on two C-line Speaker.
Double press "⏸" on one C-line Speaker. Connected prompts are heard once the speakers are paired successfully. After the first pairing, the C-line Speaker will connect

C-line speaker specifications

Power Rating	5W
Frequency Response	20HZ-20KHZ
THD	<1%
S/N	≥ 80DB
Speaker Parameter	4Ω 5W diameter 40mm
Input	12V DC
Bluetooth version	Bluetooth V5.0
Product Size	Ø55 x 47mm
Product Weight	62g

Caravan equipment

AV/TV CONNECTIONS

For TV 12 volt supply + aerial connection.

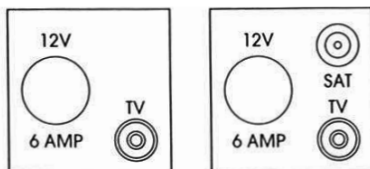

Teleco Teleplus X2 Digital Antenna System

Your caravan is fitted with a high gain, directional aerial. It receives FM, AM, MW and WN, digital and analogue signal.

Operating the system

Travelling

When positioning the antenna dome please allow for the following:

DO NOT TRAVEL:-

- With the antenna raised.
- With the antenna set for vertical signals. To reduce the possibility of damage

when travelling, have the antenna pointing towards the rear of your caravan/motor home.

Operating

1. Loosen the Mast Locking Collar and raise the antenna.
2. Determine whether the TV transmissions are horizontal or vertical and position accordingly.
3. Switch ON the amplifier and the LED will illuminate and check the gain is set to MAX by rotating the button.
4. Rotate the mast until the transmitter has been located.
5. Turn on your television set and tune in. This will be necessary at all new locations.
6. Secure the antenna by hand tightening the Mast Locking Collar.

IMPORTANT

You may detect more than one transmitter. Choose the position that gives you the

most channels when tuning in your TV.

In strong signal areas you may need to reduce the gain by rotating the control anti-clockwise.

Fault finding

The following are some of the key areas we suggest you check which generally solve the most common problems encountered with the operation of the Teleco Teleplus X2 antenna.

Coaxial Connections

It is critical that all connections in the system are fitted correctly. Please check all connectors ensuring they are wired correctly. Secondly please ensure only quality plugs have been used.

Coaxial Cable

Sharp bends, kinks and hot surfaces can easily damage coaxial cable and should be avoided. Coaxial cable, if placed in close proximity to electrical cables, transformers or other pieces of electrical equipment, may pick up electrical interference causing

picture quality to deteriorate, especially in poor reception areas. Excess cable should be removed and NOT coiled as this may cause picture distortion. An inspection of the routing of the cable is highly recommended to ensure all is correct.

Gain Control

In normal use the button should be rotated clockwise for maximum. In strong signal areas the amplification may need to be reduced. To reduce amplification rotate the button anti-clockwise until picture quality improves. The dial rotates through approx. 240 degrees from Max to Min. Pay attention not to force the dial past its end stops as this will cause it to break.

LED Light

Should the LED on the amplifier not light, firstly check there is power to the unit. Secondly check the polarity is correct. Otherwise contact Grade UK Ltd for further assistance.

Short Hook Up - Test 1

This test isolates the wiring from the

amplifier through to your TV/radio points.

Unplug the coaxial plugs from the 'TV' sockets of the amplifier and using a TV flylead with an F-connector fitted at one end, connect your TV to the amplifier.

Please ensure the antenna dome is plugged directly into the 'ANT-IN' socket of the amplifier and switch on. Tune in your TV for the strongest signal.

If the picture quality improves the fault lies with the wiring of the system between the Amplifier and the TV outlet socket.

Short Hook Up - Test 2

This test isolates the amplifier by connecting your TV direct to the antenna.

Unplug the antenna from the amplifier and connect the antenna directly to your TV. Tune in your TV for the strongest signal.

If the picture quality improves, the fault lies with the Teleco AT412 Amplifier.

Antenna Dome Coaxial Cable

Check the routing of the coaxial cable from

the antenna dome to the amplifier. Check to ensure there are no kinks or trapped cable or if there are loops of surplus cable which could be affecting performance.

Reception Troubleshooting

- If there are issues with the TV signals, then try some of the steps below:
- Is the tapered end of the antenna pointing towards the nearest local transmitter?
- Do all connectors appear to be correctly seated as far as can be seen? The cable from the mast must run to the 'Ant-in' on the amplifier.
- Are there any obvious obstructions in the vicinity that may impair reception?
- What position is the mast in?
- Main TV transmitters broadcast horizontally, whilst relay transmitters may broadcast with vertical signals.
- Has the antenna been tried in more than one location? As with radio, TV coverage varies geographically.

Caravan equipment

- Is the amplifier turned on via the rocker switch, also has the 'gain wheel been adjusted?
- Depending on the broadcasting region and vehicle location, not all usual TV channels may be received.

SIGNAL	SYMPTOM	ACTION
Very Poor	No picture or sound, TV freezing severe pixellation, break up and picture drop out.	Check the amplifier gain is set to maximum (rotate clockwise). Check antenna alignment which must be directed at the transmitter. Ensure the antenna's polarity is correct, whether horizontal or vertical.
Poor	Moderate pixellation and sound distortion.	Bypass the amplifier by following "Short Hook-Up Test 1".
Medium	Minor pixellation, will not receive all channels.	
Good	Stable picture, good sound quality, will receive all channels.	N/A
Strong	Possible pixellation, picture break up and drop out.	Reduce the amplifier gain (rotate anti- clockwise). Rotate antenna AWAY from the transmitter.
Very Strong	No picture or sound, TV freezing, severe pixellation, break up and picture drop out.	Rotate antenna AWAY from the transmitter. Switch "OFF" the amplifier and turn the gain control to maximum (rotate clockwise).
<p>After performing any of the "Actions" above you must re-tune your TV.</p>		

Mobile alarm system (where fitted)

Manufactured exclusively for Phantom by their partners at Gemini, the VanGuard alarm is designed to secure your caravan simply and reliably. The standard alarm incorporates an electronic tilt sensor and a wireless Passive Infrared sensor (PIR) along with 2 four button remotes.

The alarm does have the facility to turn the awning light on during the arm and disarm process. This is likely only available where your alarm is factory fitted. The PIR can be excluded if necessary and the sensitivity of the tilt sensor adjusted where required.

System arming

The alarm unit can be armed by pressing the arming button. Two high-pitched beeps will confirm the operation and the dome light will turn ON for approx 30 sec. The system has a 30 sec arming delay which allows you to exit the vehicle without triggering an alarm. After the arming delay, the system is fully armed.

If the PIR sensor battery level is becoming exhausted, a 'Bop' will sound after the arming acoustic signals (replace PIR internal batteries. Use only 2 CR2032 batteries.).

System Disarming

To disarm the system, press the disarming button 2 on the remote control. Three high-pitched beeps will confirm disarming and the dome light will turn ON for approx 30 sec.

System arming without internal sensors

The system can be armed without enabling the wireless PIR sensor(s). To do so, press button 3 on either remote control to arm the system. One high-pitched beep will be confirmed the system is armed with the sensors excluded.

Tilt sensor exclusion

Arm the alarm as usual by pressing button 1. After the usual two beeps wait 4 seconds and press button 3. Tilt sensor exclusion is confirmed by one beep.



NOTE:

Sensor exclusion is bound to a single arming cycle. Sensors will automatically be enabled the next time the alarm is armed.

Tilt sensor adjustment

The TILT sensor sensitivity level is factory set to trigger an alarm if the vehicle is tilted at an angle of approx 1.5° with respect to the x,y and z-axis.

Caravan equipment

Awning light

Arming/Disarming the alarm will activate the awning light for 30 seconds. Button 4 on the remote will also activate the light for 5 minutes before automatically turning off.

Typically awning light controls will only be possible with factory installations.

Alarms

An alarm event will trigger the siren for a maximum of 30 seconds. If the alarm condition remains or the alarm is not disarmed it will trigger another cycle after a pause of 5 seconds. Each alarm condition will trigger a maximum of 8 cycles.

Alarm trigger memory

If there had been an activation in your absence it will be signaled by 2 long beeps on disarming, followed by a number of high pitched 'chirps' to indicate the cause of the last trigger.

Pairing new devices

The alarm is supplied with 2 remotes and a wireless PIR sensor but extra sensors can be added via the LEARN button.

Press the LEARN button 5 times in a row within 5 seconds. Each press will generate a single beep and then a final 2 beeps will confirm the system is in pairing mode for the next 30 seconds.

Press one of the new remote buttons or trigger the sensor to be paired. A single beep will confirm the new device is added. To exit pairing mode press the LEARN button once.

Warning

The alarm memory has 12 slots. Trying to save any further devices will delete the first one.

Battery Replacement

When the remote battery are too weak you'll notice the blue LED flicker/flash when arming or disarming the alarm. Replace the CR2032 battery.

If the PIR battery is running low a secondary "bop" will sound after the usual arming 2 beeps of the siren. To replace the batteries detach the cover of the PIR from its mounting base.



Register online to validate your warranty for your vanguard alarm.

www.phantom.uk.net/vanguard

Dometic Safe
(where fitted)

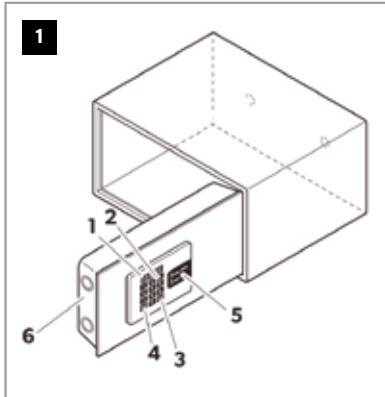

Safety instructions

The manufacturer accepts no liability for damage in the following cases:

- Damage to the product resulting from mechanical influences.
- Alterations to the product without express permission from the manufacturer.

- Use for purposes other than those described in the operating manual.

Warning

- This device can be used by children aged 8 years or over, as well as by persons with diminished physical, sensory or mental capacities or a lack of experience and knowledge, providing they are supervised, or have been taught how to use the device safely and are aware of the resulting risks.
- Only use the product as intended.
- Do not make any modifications or alterations to the product.

NOTICE:

- No unauthorised persons should have access to the master code.

Scope of delivery

- Safe
- Installation and operating manual (on request).

Technical description

The control panel has a display and a key pad for entering the code. A master code is available for opening in an emergency.

The model can be identified from the type plate.

Control elements

No. in fig.1	Description
1	Display
2	Number keys
3	CLOSE button Closes the safe lock after code is entered
4	CLEAR button Cancels the code entered
5	Lock for master key (behind cover)
6	Locking mechanism cover

Caravan equipment

Using the safe

Closing the safe



- Enter a four digit code.
- Press the **CLOSE** button.
- ✓ The display shows the message **CLOSED**.

Opening the safe



- Enter the correct four digit code.
- ✓ The code entered is shown in the display.
- ✓ The safe will open.
- ✓ The display shows the message **OPEN**.

NOTE:

If an incorrect code is entered, the message **E-CODE** appears on the display.
After five incorrect attempts, the safe lock will remain blocked for 15 minutes and no further entries are possible. As soon as a button is pressed, the message **HOLD15** appears on the display.

Emergency opening using master code

The master code is necessary if guests have left the safe locked or have forgotten their code.

Opening safe with the master code



- Enter the correct six digit master code.
- ✓ The display shows the message **OPEN**.
- ✓ The door opens.

Changing the master code

⚠ NOTICE!

- If you forget your master code, nobody can access the safe any more (not even the manufacturer). No resetting, or similar action, is possible.
- Therefore note down the master code and store it very carefully in a safe location.
- The safe has a factory setting code. We strongly recommend that you change this code for security reasons.

You can change the factory setting code (888888). The safe must be **opened** for this.

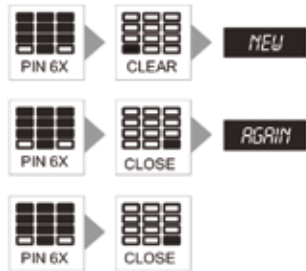

- Enter the correct six digit master code.
- Press the **CLEAR** button.
- ✓ The display shows the message **NEW**.
- Enter a new six digit master code.
- Press the **CLOSE** button.
- ✓ The display shows the message **AGAIN**.
- Repeat the entry of the new six digit master code.
- Press the **CLOSE** button again.

- ✓ The safe confirms the change of the master code with the message **DONE**.

Replacing the batteries

The batteries must be replaced after no later than one year. The batteries must also be replaced immediately if "LO-BAT" is shown on the display.

NOTE:

- Use four high-quality alkaline AA/LR6 batteries (1.5 V).
- Pay attention to the polarity.
- Always change all batteries at the same time.

- Take off the cover.
- Remove the four used batteries from the battery compartment.
- Insert four new AA batteries into the battery compartment.
- Replace the cover over the interior section.

Caravan equipment

Display messages

	Display	Sound
Press CLEAR		1 beep
Press CLOSE		1 beep
Key in guest code to open the safe	OPEN + OPENED	2 beeps
Key in guest code to close the safe	CLOSE + CLOSED	1 beep
Incorrect sequence or error entering code	E-CODE	3 beeps
Enter new master code	NEW	
Repeat master code	AGAIN	
After changing the master code	DONE	1 beep
Low battery detected	LO-BAT	
3 x error entering code	HOLD15	3 beeps
Error in locking mechanism while opening	E-RUN	2 beeps
Error in locking mechanism while closing	E-RUN	2 beeps

Troubleshooting

Display	Fault	Possible cause	Suggested remedy
LO-BAT	The safe lock doesn't close.	The battery is low.	<ul style="list-style-type: none"> ▶ Replace the batteries.
E-CODE	Three short audible signals sound.	False code	<ul style="list-style-type: none"> ▶ Enter the correct code.
	-	False master code	<ul style="list-style-type: none"> ▶ Enter the correct master code.
HOLD15	Two short audible signals sound whenever any button is pressed.	The safe lock is disabled after the wrong code has been entered three times.	<ul style="list-style-type: none"> ▶ Wait for 15 minutes without pressing any buttons. The safe lock is no longer disabled following this 15 minute waiting period. ▶ Following this, enter the correct code. ▶ Open the door mechanically with the master key.

If you are unable to rectify the fault, get in touch with a specialist workshop.

Maintaining and cleaning the safe

⚠ NOTICE!

Do not use sharp or hard objects or cleaning agents for cleaning as these may damage the product.

- Occasionally clean the product with a damp cloth.

Warranty

The statutory warranty period applies. If the product is defective, please contact the service partner in your country (addresses on the back on the instruction manual).

Our experts will be happy to help you and will discuss the warranty process with you in more detail.

Technical data

	Dometic XSafe		
	MD450	MD 390	MD310
Capacity:	30.4 l	31.5 l	9 l
Dimensions H x W x D:	200 x 450 x 400 mm	200 x 390 x 470 mm	165 x 310 x 235 mm
Gross weight:	15.1 kg	14.9 kg	8 kg
Net weight:	14.5 kg	14.3 kg	7.7 kg

Beds and bunks

Front double bed

The two front single beds can be converted into a double bed by pulling the central slats until they are fully extended. Re-arrange the seat appropriately.

Prior to tilting the single beds to access storage, please ensure the backrest is laid flat on the base cushion.

⚠ Warning

Please ensure the adjustable feet on the bed are adjusted to touch the floor/ carpet so that the bed is completely level and will not put strain onto the bed mechanism in its extended position.

NOTE: Any failures due to strain caused by non level usage are not covered by warranty.

⚠ Warning

When upper bunks are used by children especially under the age of six, care must be taken against the risk of falling out. These bunks are not suitable for use by infants without supervision.

⚠ Warning

Use high level bunks for sleeping only with protection against falling out fitted and in place.

⚠ Warning

Care should be taken when opening and closing table leg mechanisms, that fingers and limbs do not become trapped in the moving parts.

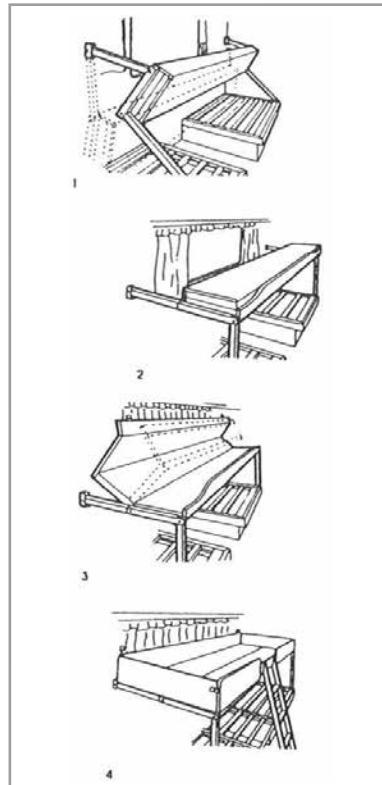

On-board Wi-Fi -

Your caravan may have been fitted with an on-board Wi-Fi antenna and modem package. The modem needs a SIM card to be activated prior to use. More details can be found in the instruction pack supplied with the unit.

The antenna is 5G ready. The router can be upgraded to 5G and is available from Teleco

Cleaning

In the interests of safety, replacement parts for an appliance shall conform to the appliance manufacturer's specification and should be fitted by him or his authorised agent.

This section of the guide is devoted to the care, cleaning and general preservation of your caravan in order to keep it in good condition.

Exterior

- Side walls of your caravan are finished

Care of your caravan

in acrylic finished aluminium, which is extremely durable and easy to clean. It is recommended that a proprietary brand of vehicle shampoo with plenty of cold water is used.

Warning

Do not use soaps or detergents containing citrus ingredients (especially limonene) as this can cause yellowing degradation of the sealant surface.

- Ideally pH should be around 7 (neutral).
- When using a concentrated soap it should be mixed with water at around a maximum of 5%.
- Always rinse with clean water after using cleaner or soap solution.
- Do not use steam cleaners especially in combination with soapy cleaners.
- Do not use a pressure washer as this can disturb the mastic seals.
- An occasional polish with a good quality vehicle wax will help obtain a high gloss

finish. **Under no circumstances should an abrasive or harsh cleaner be used.**

- Plastic and ABS panels should be cleaned using water and a mild detergent.

Under no circumstances should alcohol spirit or solvent-based liquids be used on these items, as these substances will react with the material and cause visual damage.

Lock lubrication

Lubricate all locks with Tri-Flow or any other lightweight oil (such as sewing machine oil). DO NOT use heavy grease, WD40 or silicone based lubricants.

Acrylic Windows

Your caravan is fitted with shatter resistant acrylic windows. To preserve their clarity and unblemished transparency it is essential that the following cleaning instructions are strictly adhered to:

Road grit, dust, sand, flies, lime tree secretions, bird droppings etc., should be

'swilled off' using plenty of cold water. Any remaining dirt should be washed off using a soft cloth and warm water.

Under NO circumstances should any abrasive cleaning agents, household detergents or proprietary cleaning fluids be used. Alcohol spirit or solvent-based liquids must not be used on these items as they will react with the material and cause visual damage.

Correct removal of scratches from acrylic panes is achieved by using a special polishing cloth and acrylic polishing paste. Light scratches and matt areas can be removed from acrylic by using the acrylic polishing paste and polishing cloth. Distribute the polishing paste on the pre-cleaned surface with the polishing cloth and polish gently in a circular motion for 3-5 minutes. Rinse with warm water. Do not use in strong sunshine. Correct antistatic treatment of the acrylic pane is achieved with an antistatic acrylic cleaner. The acrylic cleaner prevents the static charging and with it the attraction of dust; it removes among other things, light

stains and dust which clings loosely to the pane. Regular care with acrylic cleaner prevents the formation of a film of grime, which might be difficult to remove later, and renews constantly the antistatic effect. Spray the acrylic cleaner on the pane, with an unbroken movement wipe the surface with a fresh polishing cloth (for example: first vertically, then horizontally, but not in a circular motion!). Rub gently do not rub dry, leave to dry naturally. Do not use in strong sunshine. The acrylic panes can be enjoyed again.

It is a popular misconception that caravan windows are vacuum sealed. This is not the case.

The windows in a caravan can be susceptible to condensation if the temperature difference between inside and outside is changed quickly and dramatically, such as when a damp or cold caravan heats up quickly via a heater or the sun. This can be exaggerated particularly if the ventilation is not allowing the temperatures to balance.

The caravan window, unlike a glass window is not completely diffusion-proof, which means it is permeable to the water vapour contained in the air. That is to say that water is initially absorbed from the air on the surface of the panes. The water molecules then penetrate by diffusion into the material itself and then end up on the inside of the pane. Here they are absorbed by the air trapped between the two panes. If the water vapour in the air surrounding the window is high enough, this procedure continues until the air in the window is completely saturated.

In view of the fact that the quantity of water vapour which can be absorbed by a volume of air decreases when the temperature falls, as soon as the temperature drops the water condenses at the coldest points of the window where it becomes visible as droplets. When the pane heats up again, the water evaporates. It is in fact still there but invisible. If the air around the window becomes very dry, then the diffusion procedure starts up again through the acrylic in the other

direction. Most of the moisture disappears from the window.

It should be noted that the diffusion procedure through the window is relatively slow.

It is true condensation can be the result of window delamination but for a quantity of windows to delaminate on the same caravan would be extremely unlikely and the real test is "do the windows eventually clear".

Condensation actually occurs when the humidity inside the caravan exceeds 60% and the ventilation is not sufficient. To help overcome this some of the following actions can be taken:

- Leave the rooflight open.
- Put windows onto night vent position.
- Leave doors between compartments open.
- Keep temperature at night to minimum.
- Increase ventilation above normal in inclement weather.

Care of your caravan

As the windows are not completely sealed, some small particles of dust / foreign bodies may accumulate on the inside face of the window panel over time. In this situation there is no process for removal.

Interior Walls

Your caravan interior walls are finished with a vinyl coating and will only require a wipe over with a damp cloth, using a mild detergent, to keep them in a good condition.

Furniture

Treat your caravan furniture as you would the furniture in your home. Polish wood surfaces sparingly with a good quality wax polish. Use a damp cloth to clean laminated surfaces.

Your furniture is made from wood or wooden based materials so it requires attention and care to maintain its beauty.

Warning

Moisture in air can cause damage to furniture. Wood expands or contracts with an increase or decrease in the relative humidity in the air. The damage can be quite visible if the relative humidity is higher than 80% for a long time. To prevent damage assure the relative humidity of air is not too high for a long time by ventilating the van.

When wood is wet, wipe it dry.
Do not just wait for the sun to dry it. The longer the water stays on the surface, the more damage it can do.

Carpets, upholstery and curtains

General facts on fabric upholstery

You may find that seat comfort is a little firm at first – this is perfectly normal and your seats will soften gradually during initial use to give you longer lasting durability. All foam can lose up to 20% of its volume during the first few months of use. This is quite normal and is not a fault.

Many pile fabrics may appear darker or shaded in different areas of the furniture. This is due to the way the direction of the pile reflects light, especially when the pile is crushed during use. This is not a fault but a normal characteristic of some types of fabric. Gentle, regular brushing with a soft brush can help raise the flattened pile and reduce the effects of pile crush.

Fabric will stretch and develop creases during use especially on seats, these 'comfort wrinkles' are to be expected and are completely normal wear and tear.

Please be aware that some fabrics have

inherent characteristics that are part of their charm.

Most upholstery fabrics will show wear due to friction from use. Pilling, the formation of little balls of fuzz on the surface of your fabric can occur with normal use. The occurrence of pilling depends on several factors, including the type fibre, the weave, the construction of the fabric itself and the type of use the fabric receives. Pilling is a natural occurrence in certain upholstered fabrics and is not considered a defect.

Care of fabric and upholstery

It is **essential** that all cushions are 'dressed' regularly. Vigorous plumping by shaking and squeezing will redistribute the fillings, put air back into the fibres and ensure the cushions fill the cover to the correct shape.

If this dressing is not carried out, the filling can cause a mass giving the cushion a flat or lumpy appearance and/or making the covers appear baggy. This is not considered a defect.

Prolonged exposure to direct sunlight and heat can damage your fabrics and cause them to fade and potentially fray. Protect by placing your furniture away from prolonged direct sunlight or by drawing curtains or blinds.

Vacuuming helps to eliminate dirt before it becomes embedded in the fabrics.

Dust can be removed by pre-brushing gently with a soft brush.

Loose threads can be trimmed off neatly with sharp scissors.

Curtains are dry clean only and should never be laundered in a washing machine.

Spillage and stains

Due to the variety of fabrics used, these instructions are for general guidelines only.

Soiling can occur from the clothing you wear when using your upholstery and some fabrics, for example denim can transfer dye onto your covering. Newspaper ink from your hands or direct from the paper will stain very readily. Food

and drinks can soil and stain the material and any accidents should be dealt with straight away. Liquids need to be soaked up quickly.

Please see the below guidelines on removal or spillages and stains:

- Do not soak or allow fabrics to get wet.
- Never rub or scrub with wet cloth to remove spills or stains as this will damage the fabric and can remove colour.
- Do not use washing liquid, detergents or bleach to remove stains.
- Liquid spills: blot or soak up immediately using dry, soft colour absorbent cloth using a dabbing action.
- Solid spills (food and mud): remove excess gently before dabbing to clean stains.
- Water based stains: dab using a specialist upholstery shampoo sparingly. Do not soak.
- Pen, ink, fruit or blood: use a

Care of your caravan

specialist cleaner.

- Oil based stains (butter, margarine, cream etc.): use a spot remover containing dry cleaning fluid which can be obtained from most supermarkets or hardware stores. Follow manufacturer's instructions, testing products on a hidden area first to ensure it does not damage fabric or affect colours.
- For stubborn spots and stains we recommend professional cleaning by a specialist service.

Argent Stainless Steel Sink

Routine Cleaning

It is good practice to clean equipment immediately after use. Most deposits can be removed by washing with soap or mild detergent and hot water, followed by a clean water rinse and drying with a soft cloth to prevent water spotting. For more tenacious deposits a non-abrasive multi-purpose cream cleaner may be used. This should be applied with a soft damp cloth followed by a clean water rinse and drying.

Stubborn dirt and grease may require the use of nylon scouring pad (such as Scotchbrite), in conjunction with the multi-purpose cream cleaner.

Oil, grease and fingerprints can generally be removed with a soap/water solution but a hydrocarbon solvent may be required.

Care must be taken to use the proper safety precautions if using solvents. Fingerprints, on the glass lid, can be eliminated with a glass cleaner. Removal of the excess cleaner with a soft cloth leaves a protective film from which fingerprints can be wiped.

Tannin (Tea) Stains

Tannin stains can be removed using a hot solution of sodium carbonate (washing soda) and water, alternatively, the solution can be applied with a soft cloth/sponge. This treatment should be followed by a clean water rinse to remove any residues and drying with a soft cloth.

Heat Tinting and Discoloration

Heavy oxidation is unlikely to occur

during normal usage. If heat tinting does occur, slight abrasion of the surface will be required and the type of cleaner will depend upon the original finish of the component. A highly polished surface will require the use of a proprietary stainless steel polish but slight scratching may occur during the polishing treatment. If the finish is directional, as in a ground, brush or dull polish, then a nylon scouring pad/ cloth in conjunction with the multi-purpose cream cleaner can be used.

Scratches

Scratching will be most noticeable on highly polished components, in particular the drainer area of sinks where hard objects are likely to be placed during normal household use. These marks are usually only superficial and can be removed with a proprietary stainless steel cleaner/polish. A useful alternative is a car paint restorer, such as 'T-Cut'.

Rust Marks

Under normal usage, it is unlikely that these marks will be caused by rusting

of the stainless steel itself, but are more likely to be the result of small particles of "ordinary steel" which have become attached to the surface and subsequently rusted. These brown marks are usually only superficial stains and can be removed by using a soft damp cloth and multi-purpose cream cleaner. Occasionally, it may be necessary to resort to a proprietary stainless steel cleaner, to return the surface to its original condition.

Cautions

1. Cleaning agents containing sodium hypochlorite (bleach) should not be left in contact with stainless steel. This includes many of the new "trigger-dispense" cleaning products and some multi-purpose cream cleaners. If bleach is necessary, it should be used only in the strengths prescribed by the manufacturer and never left in contact with the surface for longer than 30 minutes, after which the stainless steel should be rinsed thoroughly with clean water.
2. On no account should "wire wool" pads be used unless they are made of stainless steel.
3. Harsh abrasives and scouring materials should not be used for cleaning stainless steel as they will leave scratch marks in the surface and damage the appearance of the article. Likewise, do not use wire brushes, scrapers or contaminated scouring pads.
4. If the article has a directional polished grain, any cleaning with abrasives should be carried out along this grain and not across it.
5. After use, always remove wet cleaning aids (such as cloths, pads, containers) from the surface, to avoid formation of water marks/stains.
6. Most domestic dishwashing liquids contain chlorides. If they are left in long-term contact with stainless steel, pitting corrosion may occur.
7. Silver Dip cleaners are particularly harmful as they contain strong

acids which can very quickly cause discoloration and pitting. If this type of cleaner comes into contact with the surface of a stainless steel article, it should be rinsed off thoroughly with clean water.

Ovens

Only clean ovens with soap and water.

Shower Room and Wash Basin Fittings

Always put the cold water into the wash hand basin before adding the hot. Thermoplastic products such as basins and showers have an adequate but limited resistance to high temperature. 70°C normally should be considered the maximum temperature the products can withstand. Bear in mind the maximum comfortable for human skin is approximately 40°C!

The normal effect of overheating on plastics is distortion of the surface, although perhaps unsightly this does not generally affect the practical application of the product.

Care of your caravan

The best way to keep the surface clean is by regular conventional soap and water and clear rinsing in cold water. For stubborn stains Thetford Bathroom Cleaner is recommended. The use of any other cleaners may harm the product, cause premature failure and will invalidate the warranty.

Abrasive products should never be used and the same applies to solutions such as nail varnish remover (Acetone), linseed oil based products (such as putty), thinners, pine oil, etc.

Thetford Bathroom Cleaner is available from most good caravan dealers.

Water Systems

The water systems, and in particular storage tanks, in caravans are susceptible to contamination by bacteria if care is not taken with their use and cleaning. The symptoms caused by bacterial contamination are not purely limited to gastro-intestinal diseases, but may also manifest themselves as ear, nose, throat, eye or skin infections. It is therefore

important that you carry out the following procedure prior to using the caravan each time, even if you boil or filter all water you use for drinking.

Containers

1. All water remaining in the container should be disposed of so that the container is empty.
2. The outside of the container should be thoroughly cleansed and washed down to remove any dirt, dust or other contaminant. Water at a suitably hot temperature containing an appropriate detergent is recommended for this purpose.
3. Water should be put into the container swirled round, then emptied out.
4. The container should then be totally filled with water containing an appropriate disinfectant/sterilant solution and allowed to stand for the recommended contact time.
5. The solution should be emptied from the container.

6. The opening of the container should be cleaned thoroughly with an appropriate pre-prepared wipe impregnated with a disinfectant/sterilant.
7. The container should be inverted whilst stored overnight (if possible).
8. The container must be filled with mains water only and mains water only should be used for the above cleaning procedure.
9. On no account should garden hoses be used to fill water tanks.

Systems

1. Drain down the system (Open all taps to allow air in, enabling the system to drain quickly), using the floor mounted drain taps.
2. Remove any water filters fitted, and replace with a short length of hose or empty filter cartridge (this will ensure the filter is not affected by the disinfectant/sterilant solution).
3. Fill the system by using the pump with

a disinfectant/sterilant solution. (Check that the solution at full strength appears all taps/showers). Allow to stand for the recommended period of time.

4. Drain the system down completely, as 1.
5. Thoroughly clean the outside of all taps/connectors with a cloth soaked in the disinfectant/sterilant.
6. Flush the system through with clean drinking water until no traces of disinfectant/sterilant can be detected at any tap.
7. Replace the filter.

Suitable sterilising chemicals are available from your caravan dealer, accessory shop, chemists, or home-brew shops. It is not, however, recommended to use bleach or sodium metabisulphide.

Winterisation & storage

If the caravan is to be stored for any length of time, especially over the winter period, the following operations are recommended.

- Remove all linens, blankets, cushions, clothes, mattresses, etc. which could be affected by damp conditions. Clean the caravan inside and out as detailed in the previous section.
- **IT IS RECOMMENDED THAT MOISTURE CAPTURE CONTAINERS ARE PLACED WITHIN YOUR CARAVAN** to aid against the effects of condensation and that these are emptied regularly.
- Drain off the water system. (See previous section).
- Leave all taps open to allow any residue to expand if frozen.
- Hang the hose for the shower to allow all residue water to drain.
- Drain and sterilise the toilet. (See previous section).
- Ensure all windows, roof lights and doors are correctly fastened and locked. Check fixed ventilation apertures are not obstructed.
- Open all the cupboard doors to allow air to circulate.
- Ensure that the alarm PIR's view of the caravan interior is clear and not obscured by items stored on the floor.
- Check that the site you have chosen to store the caravan is open, fairly high and dry and if possible not exposed to gales etc. If this proves impossible it is recommended that the caravan chassis is anchored to the ground.
- Ventilate the caravan regularly during storage period (this is most important when a caravan cover is fitted). N.B. Caravan covers must be of a breathable material.

Jack up the caravan (use bottle or screw jack, do NOT use the corner steadies) so that the wheels are clear of the ground. Support the caravan axle with wooden blocks, axle stands or similar so that when the jacks are removed the wheels remain clear of the ground. Lower the corner steadies to 'just' site the caravan. Cover the tyres to prevent deterioration.

Care of your caravan

Release the handbrake. Rotate the wheels at regular intervals to maintain wheel-bearing lubrication. Grease the over-run and shroud in a waterproof protective cover. Grease must not be used if an AKS or similar stabiliser is fitted.

Switch off 12 volt supply.

SECURITY: Lowering and locking the corner steadies and removing the wheels reduces the risk of caravan theft.

NOTE: Do not work under the caravan unless the corner steadies are down and the axle is supported.

Should the caravan be stored for a prolonged period of time it is strongly recommended that the caravan is fully serviced before the commencement of use. Your dealer will ensure that your caravan is safe, secure and ready for your enjoyment.

NOTE: Caravans stored for any length of time should not have the handbrake applied. Ideally the wheels should be removed and the caravan placed on winter

wheels and the handbrake released. The hitch head should be checked to see that it is fully extended and that there is no load on the braking system.

Maintenance - AL-KO Lightweight Chassis

AL-KO Galvanised Chassis

Hot dip galvanising offers high corrosion protection by forming a barrier layer through reaction with the atmosphere. This will be apparent by the chassis members changing to a light grey colour. During winter periods or storage where there is insufficient air circulation or heavy moisture, a soft porous, light grey oxidation layer may form. This is known as 'White Rust' and should NOT be confused with rust.

The Axle

The AL-KO rubber suspension axle has been designed for new standards of spring comfort and is maintenance free.

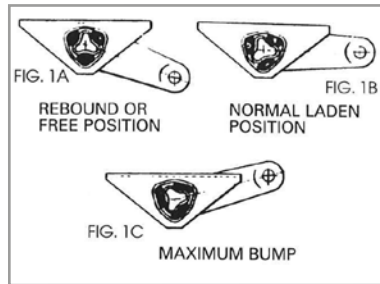

Three rubber elements are contained within a hexagonal axle tube. These provide suspension and have inherent damping characteristics.

Figures 1(A), (B) and (C) show the deformation of the rubber elements at the extremes of suspension movement.

The axle is designed to ride with the suspension drop arm at, or slightly below, the horizontal position.

Suspension shock absorbers

All Coachman caravans are fitted with AL-KO Octagon Shock Absorbers to provide increased damping characteristics and to improve road holding.

Operation of braking system (Figs 2 and 3)

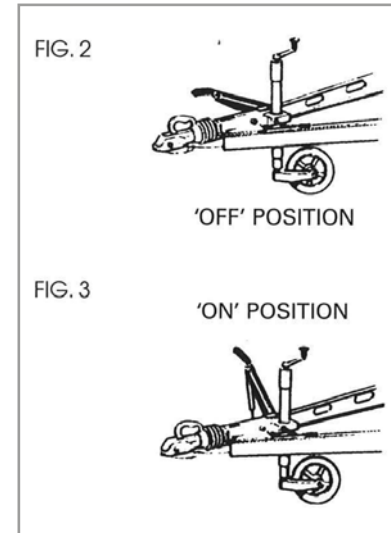

Maintenance

Forward braking

In the free position, with the handbrake fully forward in the OFF position, the drawshaft of the overrun device is fully extended and the shoes are clear of the drum.

As the towing vehicle brakes, or starts to drive downhill, the drawshaft of the overrun device is depressed toward the unit being towed. This action imparts linear motion to the main shaft of the overrun device which is transmitted via the overrun lever, brake rod and Bowden cable to the expanding clutch. This mechanism forces the leading brake shoe and by reaction, the trailing shoe outwards into contact with the drum.

Friction between the brake shoes and the drum creates a tendency for both shoes and the expanding clutch to move in the direction of forward rotation until they abut the adjuster box. This ensures that both shoes remain in the braking position.

Reversing

When the towing vehicle reverses, the drawshaft is pushed backward, moving the overrun device through its full travel. This movement is transmitted in the normal manner to the expanding clutch.

The clutch forces both shoes into contact with the drum. Initial friction between these creates a tendency for the shoes and the expanding clutch to move in the direction of the wheel rotation i.e. reverse. This movement imparts pressure to the spring-loaded auto-reverse lever, causing it to collapse. Thus, friction between the shoes and drum is almost eliminated, allowing the trailer to reverse in concert with the towing unit.

Slight forward movement of the chassis will allow the coiled spring to reassert itself, enabling the reverse lever to recover to its normal position. Normal braking is then immediately available.

Parking

The AL-KO parking brake system incorporates a patented device for added safety when parking on a reverse-sloping site or steep hill.

The AL-KO parking brake system comprises a handbrake lever mechanism actuating a Bowden cable, which operates a brake unit assembly, contained within the wheel hub.

AL-KO's unique parking brake system requires a source of stored energy to lock the wheel brakes should the trailer start to move after it has been uncoupled from the towing unit.

This energy source is provided by a spring cylinder acting as an energy store.

Wheels and tyres

Wheels

The AL-KO chassis is supported on road wheels fitted with pneumatic tyres. The size of wheel and type fitted to the chassis is dependent upon the load to be towed.

Each chassis is provided with an adjustable jockey wheel, which is clamped inboard directly to the overrun device. The jockey wheel provides stabilisation and is fitted with a solid tyre.

Spare wheel chassis mounted

Each Coachman caravan has a unique AL-KO Group spare wheel carrier mounted on the chassis under the caravan.

The carrier is of extra strong, lightweight construction and is easy to operate. Detailed operating instructions are included under the heading "Changing a Wheel" on page 29.

Tyres

Please refer to Technical Data section for information regarding wheel and tyre sizes.

Pressures

It is customary for tyre manufacturers to mark tyres with load and inflation data. **This information relates to the use of the tyre on cars. This is not the operating**

or maximum pressure when used on a caravan.

Please refer to the technical supplement for information regarding tyre pressures.

It is dangerous to drive with under inflated tyres. The pressures (cold) recommended by the manufacturer should be adhered to.

Pressure checks, including those on the spare tyre, should be made with the tyres cold and using an accurate pressure gauge. The checks should be carried out before each journey and at regular intervals during storage.

Tyre wear and damage

The legal requirements for tread depth on motor vehicles' tyres applies also to caravans. Similarly, it is not permitted to mix cross-ply and radial tyres on the same axle. A redundant tyre must be replaced by one of the same size and construction.

Wheels should be balanced and changed round occasionally to equal wear and prolong the life of the tyres. A tyre should be renewed if a blister, rupture or cut

exposing the casing is detected. If the tyre has suffered violent impact (e.g. against a kerb), it should be examined by a specialist as soon as possible.

As from April 1987 the speed limit in the UK when towing a caravan was raised from 50mph to 60mph where permitted.

Recommended lubricants

Mobilgrease MP is recommended for all greasing routines. A good all-purpose oil is recommended for general use.

AL-KO Group EURO-AXLE

Description

Retaining the well-proven AL-KO group Hexagonal rubber independent suspension, the specific features of the AL-KO group Euro-Axle are:

- Bolted on wheel brakes.
- Adjustable toe-in and camber (factory only).
- Strengthened stub axle. Sealed for life bearing unit.

Maintenance

- Octagon Shock Absorbers.

In addition the backplate has a 'gold' coloured, zinc passivated finish.

All Euro-Axles can be positively identified by the axle date plate.

Important note

The toe-in and camber is factory set and must not be altered.

Braking System adjustment must be carried out by an Approved Dealer.

AL-KO braking system adjustment

This must only be undertaken by an Approved Dealer.

Changing a wheel

(see section "Towing and Driving")

Before fitting a new wheel, examine it for distortion or other damage. Ensure that all mating surfaces are clean and dry, including bolt seats.

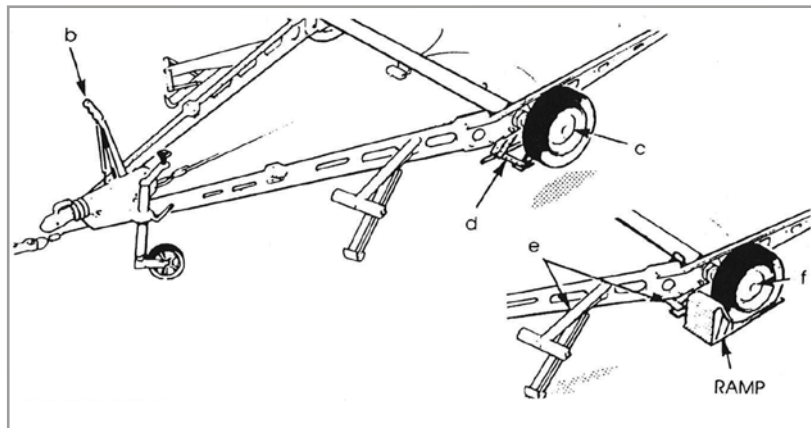

ALWAYS USE THE CORRECT BOLTS TO SECURE THE WHEEL. THERE ARE UNIQUE BOLTS FOR ALLOY WHEELS AND UNDER NO CIRCUMSTANCES SHOULD ANY OTHER BOLTS BE USED WITH ALLOY WHEELS.

Alloy wheel bolts are stamped with 10.9 and may be used with steel wheels.

A corner steady brace is not to be used for the next step.

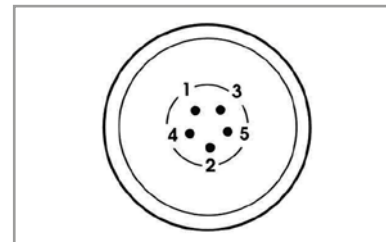

- Fit the new wheel and refit the wheel bolts.

WARNING – Ensure the wheel is of the same construction and size with the one that has been removed

Tighten all bolts equally in the order shown in the diagram.

Torque settings are:

Steel Wheels 88Nm (65lbsft)
Alloy Wheels 130Nm (96lbsft)

NOTE: With alloy wheels you should first tighten all the bolts to 85Nm (63lbsft) then go round again in the sequence shown and increase the torque from 85Nm (63kbsft) to 130Nm (96lbsft).

- Raise the corner steadies. Take the weight of the caravan onto the jack and remove the axle stands or ramping boards.
- Lower the caravan to the ground.

Jacking

Under no circumstances should the corner steadies be used to jack up the unit.

When it is necessary to jack up use a bottle, screw or scissor type jack with axle

shaped head. Place the jack plate under the axle tube as near as possible to the main chassis member.

Lubrication

Lubricate the Jockey Wheel

Lightly oil the wheel axle and screw thread.

Lubricate the Brake Linkage

Lightly oil all moving parts.

Lubricate the Corner Steadies

Lightly oil the screw and pivot pins.

For more information concerning the chassis and under gear please refer to the AL-KO handbook contained within your document wallet.

Servicing

It is a condition of warranty that your caravan is serviced once a year by a competent Service Centre. Proof of this will be required in the event of a warranty claim.

The Coachman warranty does require that servicing must be carried out as per the service schedule (refer to service &

warranty manual) and must include the original VAT invoices and a full damp check.

Your caravan also requires servicing at least once a year for safety, efficiency and to protect the investment you have made. Whether the caravan is used for short trips or continental long range touring, regular servicing is necessary and will ensure continued enjoyment of your caravan.

Dealers will carry out your annual servicing using the latest techniques and equipment (a list of the items to be inspected, tested and adjusted appears in this handbook), and will complete the service document as proof of regular maintenance.

As with motor vehicle service documents, not only will the proof of regular servicing enhance your caravan's resale value but in the unlikely event of any defect appearing at some later date it is vital that service history can be identified. We suggest service invoices are retained with the service & warranty manual.

Warranty

Manufacturer administrating warranty with dealerships:

Appliance/ Component	Address of company providing warranty	Warranty Term	Contact no.
Chassis, axle & under gear hitch, traction control and wheel lock (where fitted)	AL-KO, South Warwickshire Business Park, Kineton Road, Southam, Warwickshire CV47 0AL	36 months	01926 818500
Alarm (where fitted)	Phantom Ltd, 154-156 Higher Hillgate, Stockport, Greater Manchester, SK1 3QT	24 months	0161 476 4050
Polyplastic windows	Miriad Products, Dovefields Industrial Estate, Uttoxeter, ST14 8HU	Optical 3 months Technical 24 months	01283 586 060
Power centre / chargers / loom / relays / consumer unit control panels	BCA Leisure Limited, Unit H9 Premier Way, Lowfields Business Park, Elland HX5 9HF	36 months	01422 376977
Refrigerator, toilet, cooker and hob	Thetford Limited, Unit 6 Brookfields Way, Wath Upon Dearne, Rotherham S63 5DL	36 months	0844 997 1960
Toilet, cooker and hob		36 months	
Soft furnishings	Leisure Furnishings Limited, Unit 4, Meadow Brooks Business Park, Meadow Lane, Long Eaton, NG10 2GD	24 month Fabric light fastness 12 months	0115 946 3666
Heating systems	Alde International (UK) Limited, Huxley Close, Park Farm South, Wellingborough NN8 6AB	36 months	01933 677765
Water systems	Whale, 2 Enterprise Road, Bangor, Co. Down, Northern Ireland BT19 7TA	36 months	028 9127 0531
Gas components		36 months	
Phantom Tracker (where fitted)	Phantom Ltd, 154 - 156 Higher Hillgate, Stockport, Greater Manchester, SK1 3QT	12 months	0161 476 4050
Smoke alarm	Carafax, Unit 10b Rotterdam Road, Suttin Fields Industrial Estate, Hull, HU7 0XD.	36 months	01482 825941
Carbon monoxide alarm		60 months	
Solar panel and regulator (where fitted)	Truma Limited, 200 Park Lane, Dove Valley Park, Foston, Derby DE65 5BG	36 months	01283 587900
Self levelling system (where fitted)	E + P Hydraulics (Supplied by AL-KO). AL-KO, South Warwickshire Business Park, Kineton Road, Southam, Warwickshire, CV47 0AL	24 months	01926 818500
Blinds / Flyscreens	Hartal. Miriad Products, Dovefields Industrial Estate, Uttoxeter, ST14 8HU	24 months	01283 586 060
Exterior doors	Miriad Products, Dovefields Industrial Estate, Uttoxeter, ST14 8HU	36 months	01283 586 060
Carpet set	Kustom Sports, Unit 6, Middlewoods Way, Wharncliffe Business Park, Carlton, Barnsley S71 3HR	12 months	01226 203 347



The technical data information has been prepared to provide you with the dimensions, weights and sizes applicable to your caravan. It is recommended that you study the weight, size and tyre pressure information contained in this booklet to familiarise yourself with the specification of your caravan. For equipment operational information you should refer to additional leaflets contained in your Owners' Information Pack.

All Coachman models have been certified by the National Caravan Council for compliance with stringent European Standards, British Legislation and industry set Codes of Practice, specifically relating to health and safety issues. The approval process covers the testing and inspection of critical areas of the product from fire safety, weights and dimensions to gas, electrics and ventilation.

Every Coachman caravan carries the "NCC Approved Caravan" badge. The NCC also conducts unannounced inspections at the Coachman factory to ensure continued compliance. NCC Approval gives you peace of mind that your caravan is legal and safe.

Acadia standard specifications (based on the models below)

MODEL	460	545	575
Number of Berths	2	4	4
Interior Length	4625mm / 15' 2"	5760mm / 18' 11"	5760mm / 18' 11"
Overall Length	6255mm / 20' 6"	7390mm / 24' 3"	7390mm / 24' 3"
Overall Width	2260mm / 7' 5"	2260mm / 7' 5"	2260mm / 7' 5"
Overall Height (including TV Aerial)	2675mm / 8' 9"	2675mm / 8' 9"	2675mm / 8' 9"
Maximum Headroom	1955mm / 6' 5"	1955mm / 6' 5"	1955mm / 6' 5"
Wheel Rim	5.5J x 14	5.5J x 14	5.5J x 14
Tyre Size	185 R14 104	185 R14 104	185 R14 104
Tyre Pressure (bar / psi at quoted MTPLM)	4.5 / 65	4.5 / 65	4.5 / 65
Bed Sizes	<p>Option 1 2x Single 1840 x 700 (6' x 2' 3")</p> <p>Option 2 1x Double 2010 x 1725 (6' 7" x 5' 7")</p>	<p>Option 1 2x Single 1465 x 705 (4' 9" x 2' 4") 1x Double 1875 x 1370 (6' 2" x 4' 6")</p> <p>Option 2 1x Double 2010 x 1345 (6' 7" x 4' 5") 1x Double 1875 x 1370 (6' 2" x 4' 6")</p>	<p>Option 1 2x Single 1465 x 705 (4' 9" x 2' 4") 1x Double 1875 x 1370 (6' 2" x 4' 6")</p> <p>Option 2 1x Double 2010 x 1350 (6' 7" x 4' 5") 1x Double 1875 x 1370 (6' 2" x 4' 6")</p>
MTPLM	1343kg	1550kg	1537kg
Mass in Running Order	1219kg	1395kg	1382kg
Personal Payload	124kg	155kg	155kg
Options Payload	0kg	0kg	0kg
Total / Maximum User Payload	124kg	155kg	155kg
Maximum Hitch Weight	100kg	100kg	100kg
Upper MTPLM (Optional weight plate upgrade)	1400kg	1550kg	1550kg
Tyre Pressure (bar / psi at Upper MTPLM)	4.5 / 65	4.5 / 65	4.5 / 65

Note:- Please consult your dealer for terms and conditions regarding a weight plate upgrade to the upper MTPLM. Any imperial measurement is given as a guide only and may be subject to rounding up/down.
 * Estimated weights. Please refer to the website for confirmed weights. ** Alternative tyres maybe fitted but will be of equivalent or higher load rating. Alternative would be 185/65 R14 93N

Acadia standard specifications (based on the models below)

MODEL	660 Xtra	
Number of Berths	5	
Interior Length	6265mm / 20' 7"	
Overall Length	7895mm / 25' 11"	
Overall Width	2440mm / 8'	
Overall Height (including TV Aerial)	2675mm / 8' 9"	
Maximum Headroom	1955mm / 6' 5"	
Wheel Rim	5.5J x 14	
Tyre Size	185/70 R14 88 **	
Tyre Pressure (bar / psi at quoted MTPLM)	2.4 / 35	
Bed Sizes	Option 1 1x Single 1980 x 770 (6' 6" x 2' 6") 1x Single 1720 x 705 (5' 7" x 2' 4") 1x Single 1872 x 1032 (6' 1" x 3' 4") 1x Double 1900 x 1320 (6' 2" x 4' 4")	Option 2 1x Double 1980 x 1370 (6' 6" x 4' 6") 1x Single 1872 x 1032 (6' 1" x 3' 4") 1x Double 1900 x 1320 (6' 3" x 4' 4")
MTPLM	1805kg	
Mass in Running Order	1635kg	
Personal Payload	170kg	
Options Payload	0kg	
Total / Maximum User Payload	170kg	
Maximum Hitch Weight	100kg	
Upper MTPLM (Optional weight plate upgrade)	1900kg	
Tyre Pressure (bar / psi at Upper MTPLM)	2.4 / 35	

Note:- Please consult your dealer for terms and conditions regarding a weight plate upgrade to the upper MTPLM. Any imperial measurement is given as a guide only and may be subject to rounding up/down.
 * Estimated weights. Please refer to the website for confirmed weights. ** Alternative tyres maybe fitted but will be of equivalent or higher load rating. Alternative would be 185/65 R14 93N

Acadia dealer specials specifications (based on the models below)

MODEL	460	545	575
Number of Berths	2	4	4
Interior Length	4625mm / 15' 2"	5760mm / 18' 11"	5760mm / 18' 11"
Overall Length	6255mm / 20' 6"	7390mm / 24' 3"	7390mm / 24' 3"
Overall Width	2260mm / 7' 5"	2260mm / 7' 5"	2260mm / 7' 5"
Overall Height (including TV Aerial)	2675mm / 8' 9"	2675mm / 8' 9"	2675mm / 8' 9"
Maximum Headroom	1955mm / 6' 5"	1955mm / 6' 5"	1955mm / 6' 5"
Wheel Rim	5.5J x 14	5.5J x 14	5.5J x 14
Tyre Size	185 R14 104	185 R14 104	185 R14 104
Tyre Pressure (bar / psi at quoted MTPLM)	4.5 / 65	4.5 / 65	4.5 / 65
Bed Sizes	<p>Option 1 2x Single 1840 x 700 (6' x 2' 3")</p> <p>Option 2 1x Double 2010 x 1725 (6' 7" x 5' 7")</p>	<p>Option 1 2x Single 1465 x 705 (4' 9" x 2' 4") 1x Double 1875 x 1370 (6' 2" x 4' 6")</p> <p>Option 2 1x Double 2010 x 1345 (6' 7" x 4' 5") 1x Double 1875 x 1370 (6' 2" x 4' 6")</p>	<p>Option 1 2x Single 1465 x 705 (4' 9" x 2' 4") 1x Double 1875 x 1370 (6' 2" x 4' 6")</p> <p>Option 2 1x Double 2010 x 1350 (6' 7" x 4' 5") 1x Double 1875 x 1370 (6' 2" x 4' 6")</p>
MTPLM	1346kg	1550kg	1540kg
Mass in Running Order	1222kg	1395kg	1385kg
Personal Payload	124kg	155kg	155kg
Options Payload	0kg	0kg	0kg
Total / Maximum User Payload	124kg	155kg	155kg
Maximum Hitch Weight	100kg	100kg	100kg
Upper MTPLM (Optional weight plate upgrade)	1400kg	1550kg	1550kg
Tyre Pressure (bar / psi at Upper MTPLM)	4.5 / 65	4.5 / 65	4.5 / 65

Note:- Please consult your dealer for terms and conditions regarding a weight plate upgrade to the upper MTPLM. Any imperial measurement is given as a guide only and may be subject to rounding up/down.
 * Estimated weights. Please refer to the website for confirmed weights. ** Alternative tyres maybe fitted but will be of equivalent or higher load rating. Alternative would be 185/65 R14 93N

Acadia dealer specials specifications (based on the models below)

MODEL	660 Xtra	
Number of Berths	5	
Interior Length	6265mm / 20' 7"	
Overall Length	7895mm / 25' 11"	
Overall Width	2440mm / 8'	
Overall Height (including TV Aerial)	2675mm / 8' 9"	
Maximum Headroom	1955mm / 6' 5"	
Wheel Rim	5.5J x 14	
Tyre Size	185/70 R14 88 **	
Tyre Pressure (bar / psi at quoted MTPLM)	2.4 / 35	
Bed Sizes	Option 1 1x Single 1980 x 770 (6' 6" x 2' 6") 1x Single 1720 x 705 (5' 7" x 2' 4") 1x Single 1872 x 1032 (6' 1" x 3' 4") 1x Double 1900 x 1320 (6' 2" x 4' 4")	Option 2 1x Double 1980 x 1370 (6' 6" x 4' 6") 1x Single 1872 x 1032 (6' 1" x 3' 4") 1x Double 1900 x 1320 (6' 3" x 4' 4")
MTPLM	1808kg	
Mass in Running Order	1638kg	
Personal Payload	170kg	
Options Payload	0kg	
Total / Maximum User Payload	170kg	
Maximum Hitch Weight	100kg	
Upper MTPLM (Optional weight plate upgrade)	1900kg	
Tyre Pressure (bar / psi at Upper MTPLM)	2.4 / 35	

Note:- Please consult your dealer for terms and conditions regarding a weight plate upgrade to the upper MTPLM. Any imperial measurement is given as a guide only and may be subject to rounding up/down.
 * Estimated weights. Please refer to the website for confirmed weights. ** Alternative tyres may be fitted but will be of equivalent or higher load rating. Alternative would be 185/65 R14 93N

VIP standard specifications (based on the models below)

MODEL	460	520	545
Number of Berths	2	3	4
Interior Length	4750mm / 15' 7"	5420mm / 17' 9"	5800mm / 19' 0"
Overall Length	6380mm / 20' 11"	7050mm / 23' 2"	7430mm / 24' 5"
Overall Width	2310mm / 7' 7"	2310mm / 7' 7"	2310mm / 7' 7"
Overall Height (including T.V Aerial)	2675mm / 8' 9"	2675mm / 8' 9"	2675mm / 8' 9"
Overall Height (including Air Conditioner)	2750mm / 9'	2750mm / 9'	2750mm / 9'
Maximum Headroom	1955mm / 6' 5"	1955mm / 6' 5"	1955mm / 6' 5"
Wheel Rim	5.5J x 14	5.5J x 14	6.0J x 15
Tyre Size	185 R14 104	185 R14 104	195/70 R15 104
Tyre Pressure (bar / psi at quoted MTPLM)	4.5 / 65	4.5 / 65	4.5 / 65
Bed Sizes	<p>Option 1 2x Single 1845 x 725 (6' x 2' 4")</p> <p>Option 2 1x Double 2075 x 1720 (6' 9" x 5' 8")</p>	<p>Option 1 2x Single 1845 x 725 (6' x 2' 4") 1x Single 1835 x 720 (6' x 2' 4")</p> <p>Option 2 1x Double 2075 x 1720 (6' 9" x 5' 8") 1x Single 1835 x 720 (6' x 2' 4")</p>	<p>Option 1 2x Single 1505 x 725 (4' 11" x 2' 4") 1x Double 1880 x 1365 (6' 2" x 4' 6")</p> <p>Option 2 1x Double 2075 x 1390 (6' 9" x 4' 7") 1x Double 1880 x 1365 (6' 2" x 4' 6")</p>
MTPLM	1444kg	1540kg	1678kg
Mass in Running Order	1319kg	1398kg	1522kg
Personal Payload	125kg	142kg	156kg
Options Payload	0kg	0kg	0kg
Total / Maximum User Payload	125kg	142kg	156kg
Maximum Hitch Weight	100kg	100kg	100kg
Upper MTPLM (Optional weight plate upgrade)	1500kg	1550kg	1700kg
Tyre Pressure (bar / psi at Upper MTPLM)	4.5 / 65	4.5 / 65	4.5 / 65

Note:- Please consult your dealer for terms and conditions regarding a weight plate upgrade to the upper MTPLM. Any imperial measurement is given as a guide only and may be subject to rounding up/down.
 * Estimated weights. Please refer to the website for confirmed weights. ** Alternative tyres maybe fitted but will be of equivalent or higher load rating. Alternative would be 185/65 R14 93N

VIP standard specifications (based on the models below)

MODEL	565	575	
Number of Berths	4	4	
Interior Length	5740mm / 18' 10"	5800mm / 19' 0"	
Overall Length	7370mm / 24' 2"	7430mm / 24' 5"	
Overall Width	2310mm / 7' 7"	2310mm / 7' 7"	
Overall Height (including TV Aerial)	2675mm / 8' 9"	2675mm / 8' 9"	
Overall Height (including Air Conditioner)	2750mm / 9'	2750mm / 9'	
Maximum Headroom	1955mm / 6' 5"	1955mm / 6' 5"	
Wheel Rim	6.0J x 15	6.0J x 15	
Tyre Size	195/70 R15 104	195/70 R15 104	
Tyre Pressure (bar / psi at quoted MTPLM)	4.5 / 65	4.5 / 65	
Bed Sizes	<p style="text-align: center;">Option 1</p> <p style="text-align: center;">2x Single</p> <p style="text-align: center;">1505 x 725 (4' 11" x 2' 4")</p> <p style="text-align: center;">1x Single</p> <p style="text-align: center;">1910 x 730 (6' 3" x 2' 4")</p> <p style="text-align: center;">1x Single</p> <p style="text-align: center;">1820 x 730 (6' 0" x 2' 4")</p> <p style="text-align: center;">Option 2</p> <p style="text-align: center;">1x Double</p> <p style="text-align: center;">2075 x 1390 (6' 9" x 4' 7")</p> <p style="text-align: center;">1x Single</p> <p style="text-align: center;">1910 x 730 (6' 3" x 2' 4")</p> <p style="text-align: center;">1x Single</p> <p style="text-align: center;">1820 x 730 (6' 0" x 2' 4")</p>	<p style="text-align: center;">Option 1</p> <p style="text-align: center;">2x Single</p> <p style="text-align: center;">1505 x 725 (4' 11" x 2' 4")</p> <p style="text-align: center;">1x Double</p> <p style="text-align: center;">1875 x 1370 (6' 2" x 4' 6")</p> <p style="text-align: center;">Option 2</p> <p style="text-align: center;">1x Double</p> <p style="text-align: center;">2075 x 1390 (6' 9" x 4' 7")</p> <p style="text-align: center;">1x Double</p> <p style="text-align: center;">1875 x 1370 (6' 2" x 4' 6")</p>	
MTPLM	1672kg	1666kg	
Mass in Running Order	1517kg	1510kg	
Personal Payload	155kg	156kg	
Options Payload	0kg	0kg	
Total / Maximum User Payload	155kg	156kg	
Maximum Hitch Weight	100kg	100kg	
Upper MTPLM (Optional weight plate upgrade)	1700kg	1700kg	
Tyre Pressure (bar / psi at Upper MTPLM)	4.5 / 65	4.5 / 65	

Note:- Please consult your dealer for terms and conditions regarding a weight plate upgrade to the upper MTPLM. Any imperial measurement is given as a guide only and may be subject to rounding up/down.
 * Estimated weights. Please refer to the website for confirmed weights. ** Alternative tyres maybe fitted but will be of equivalent or higher load rating. Alternative would be 185/65 R14 93N

VIP dealer specials specifications (based on the models below)

MODEL	460	520	545
Number of Berths	2	3	4
Interior Length	4750mm / 15' 7"	5420mm / 17' 9"	5800mm / 19' 0"
Overall Length	6380mm / 20' 11"	7050mm / 23' 2"	7430mm / 24' 5"
Overall Width	2310mm / 7' 7"	2310mm / 7' 7"	2310mm / 7' 7"
Overall Height (including TV Aerial)	2675mm / 8' 9"	2675mm / 8' 9"	2675mm / 8' 9"
Overall Height (including Air Conditioner)	2750mm / 9'	2750mm / 9'	2750mm / 9'
Maximum Headroom	1955mm / 6' 5"	1955mm / 6' 5"	1955mm / 6' 5"
Wheel Rim	5.5J x 14	5.5J x 14	6.0J x 15
Tyre Size	185 R14 104	185 R14 104	195/70 R15 104
Tyre Pressure (bar / psi at quoted MTPLM)	4.5 / 65	4.5 / 65	4.5 / 65
Bed Sizes	<p>Option 1 2x Single 1845 x 725 (6' x 2' 4")</p> <p>Option 2 1x Double 2075 x 1720 (6' 9" x 5' 8")</p>	<p>Option 1 2x Single 1845 x 725 (6' x 2' 4") 1x Single 1835 x 720 (6' x 2' 4")</p> <p>Option 2 1x Double 2075 x 1720 (6' 9" x 5' 8") 1x Single 1835 x 720 (6' x 2' 4")</p>	<p>Option 1 2x Single 1505 x 725 (4' 11" x 2' 4") 1x Double 1880 x 1365 (6' 2" x 4' 6")</p> <p>Option 2 1x Double 2075 x 1390 (6' 9" x 4' 7") 1x Double 1880 x 1365 (6' 2" x 4' 6")</p>
MTPLM	1453kg	1549kg	1678kg
Mass in Running Order	1328kg	1407kg	1531kg
Personal Payload	125kg	142kg	156kg
Options Payload	0kg	0kg	0kg
Total / Maximum User Payload	125kg	142kg	156kg
Maximum Hitch Weight	100kg	100kg	100kg
Upper MTPLM (Optional weight plate upgrade)	1500kg	1550kg	1700kg
Tyre Pressure (bar / psi at Upper MTPLM)	4.5 / 65	4.5 / 65	4.5 / 65

Note:- Please consult your dealer for terms and conditions regarding a weight plate upgrade to the upper MTPLM. Any imperial measurement is given as a guide only and may be subject to rounding up/down.
 * Estimated weights. Please refer to the website for confirmed weights. ** Alternative tyres maybe fitted but will be of equivalent or higher load rating. Alternative would be 185/65 R14 93N

VIP dealer specials specifications (based on the models below)

MODEL	565	575	
Number of Berths	4	4	
Interior Length	5740mm / 18' 10"	5800mm / 19' 0"	
Overall Length	7370mm / 24' 2"	7430mm / 24' 5"	
Overall Width	2310mm / 7' 7"	2310mm / 7' 7"	
Overall Height (including TV Aerial)	2675mm / 8' 9"	2675mm / 8' 9"	
Overall Height (including Air Conditioner)	2750mm / 9'	2750mm / 9'	
Maximum Headroom	1955mm / 6' 5"	1955mm / 6' 5"	
Wheel Rim	6.0J x 15	6.0J x 15	
Tyre Size	195/70 R15 104	195/70 R15 104	
Tyre Pressure (bar / psi at quoted MTPLM)	4.5 / 65	4.5 / 65	
Bed Sizes	<p>Option 1 2x Single 1505 x 725 (4' 11" x 2' 4") 1x Single 1910 x 730 (6' 3" x 2' 4") 1x Single 1820 x 730 (6' 0" x 2' 4")</p> <p>Option 2 1x Double 2075 x 1390 (6' 9" x 4' 7") 1x Single 1910 x 730 (6' 3" x 2' 4") 1x Single 1820 x 730 (6' 0" x 2' 4")</p>	<p>Option 1 2x Single 1505 x 725 (4' 11" x 2' 4") 1x Double 1875 x 1370 (6' 2" x 4' 6")</p> <p>Option 2 1x Double 2075 x 1390 (6' 9" x 4' 7") 1x Double 1875 x 1370 (6' 2" x 4' 6")</p>	
MTPLM	1681kg	1675kg	
Mass in Running Order	1526kg	1519kg	
Personal Payload	155kg	156kg	
Options Payload	0kg	0kg	
Total / Maximum User Payload	155kg	156kg	
Maximum Hitch Weight	100kg	100kg	
Upper MTPLM (Optional weight plate upgrade)	1700kg	1700kg	
Tyre Pressure (bar / psi at Upper MTPLM)	4.5 / 65	4.5 / 65	

Note:- Please consult your dealer for terms and conditions regarding a weight plate upgrade to the upper MTPLM. Any imperial measurement is given as a guide only and may be subject to rounding up/down.
* Estimated weights. Please refer to the website for confirmed weights. ** Alternative tyres maybe fitted but will be of equivalent or higher load rating. Alternative would be 185/65 R14 93N

Laser standard specifications (based on the models below)

MODEL	480 Xtra	545 Xtra	575 Xtra	845 Xtra
Number of Berths	2	4	4	4
Interior Length	4800mm / 15' 9"	5800mm / 19' 0"	5800mm / 19' 0"	6265mm / 20' 7"
Overall Length	6430mm / 21' 1"	7430mm / 24' 5"	7430mm / 24' 5"	7895mm / 25' 11"
Overall Width	2440mm / 8'	2440mm / 8'	2440mm / 8'	2440mm / 8'
Overall Height (including TV Aerial)	2675mm / 8' 9"	2675mm / 8' 9"	2675mm / 8' 9"	2675mm / 8' 9"
Overall Height (including Air Conditioner)	2750mm / 9'	2750mm / 9'	2750mm / 9'	2750mm / 9'
Maximum Headroom	1955mm / 6' 5"	1955mm / 6' 5"	1955mm / 6' 5"	1955mm / 6' 5"
Wheel Rim	6.0J x 15	6.0J x 15	6.0J x 15	5.5J x 14
Tyre Size	195/70 R15 104	205/70 R15 106	205/70 R15 106	185/70 R14 88
Tyre Pressure (bar / psi at quoted MTPLM)	4.5 / 65	4.5 / 65	4.5 / 65	2.4 / 35
Bed Sizes	<p>Option 1 2x Single 1840 x 725 (6' x 2' 4")</p> <p>Option 2 1x Double 2000 x 1390 (7' 2" x 4' 7")</p>	<p>Option 1 1x Single 1565 x 705 (5' 2" x 2' 4") 1x Single 1980 x 770 (6' 6" x 2' 6") 1x Double 1875 x 1425 (6' 2" x 4' 8")</p> <p>Option 2 1x Double 1980 x 1370 (6' 6" x 4' 6") 1x Double 1875 x 1425 (6' 2" x 4' 8")</p>	<p>Option 1 2x Single 1505 x 725 (4' 11" x 2' 4") 1x Double 1875 x 1370 (6' 2" x 4' 6")</p> <p>Option 2 1x Double 2200 x 1390 (7' 2" x 4' 7") 1x Double 1875 x 1370 (6' 2" x 4' 6")</p>	<p>Option 1 2x Single 1980 x 770 (6' 6" x 2' 6") 1720 x 705 (5' 7" x 2' 4") 1x Double 1875 x 1425 (6' 2" x 4' 8")</p> <p>Option 2 1x Double 1980 x 1370 (6' 6" x 4' 6") 1x Double 1875 x 1425 (6' 2" x 4' 8")</p>
MTPLM	1550kg	1770kg	1739kg	1916kg
Mass in Running Order	1425kg	1615kg	1584kg	1756kg
Personal Payload	125kg	155kg	155kg	160kg
Options Payload	0kg	0kg	0kg	0kg
Total / Maximum User Payload	125kg	155kg	155kg	160kg
Maximum Hitch Weight	100kg	100kg	100kg	100kg
Upper MTPLM (Optional weight plate upgrade)	1600kg	1800kg	1800kg	2000kg
Tyre Pressure (bar / psi at Upper MTPLM)	4.5 / 65	4.5 / 65	4.5 / 65	2.4 / 35

Note:- Please consult your dealer for terms and conditions regarding a weight plate upgrade to the upper MTPLM. Any imperial measurement is given as a guide only and may be subject to rounding up/down.
 * Estimated weights. Please refer to the website for confirmed weights. ** Alternative tyres maybe fitted but will be of equivalent or higher load rating. Alternative would be 185/65 R14 93N

Laser standard specifications (based on the models below)

MODEL	855 Xtra	865 Xtra	875 Xtra
Number of Berths	4	4	4
Interior Length	6265mm / 20' 7"	6265mm / 20' 7"	6265mm / 20' 7"
Overall Length	7895mm / 25' 11"	7895mm / 25' 11"	7895mm / 25' 11"
Overall Width	2440mm / 8'	2440mm / 8'	2440mm / 8'
Overall Height (including TV Aerial)	2675mm / 8' 9"	2675mm / 8' 9"	2675mm / 8' 9"
Overall Height (including Air Conditioner)	2750mm / 9'	2750mm / 9'	2750mm / 9'
Maximum Headroom	1955mm / 6' 5"	1955mm / 6' 5"	1955mm / 6' 5"
Wheel Rim	5.5J x 14	5.5J x 14	5.5J x 14
Tyre Size	185/70 R14 88	185/70 R14 88	185/70 R14 88
Tyre Pressure (bar / psi at quoted MTPLM)	2.4 / 35	2.4 / 35	2.4 / 35
Bed Sizes	<p style="text-align: center;">Option 1 2x Single 1900 x 705 (6' 2" x 2' 3") 1980 x 770 (6' 6" x 2' 6") 1x Double 1875 x 1370 (6' 2" x 4' 6")</p> <p style="text-align: center;">Option 2 1x Double 1980 x 1370 (6' 6" x 4' 6") 1x Double 1875 x 1425 (6' 2" x 4' 8")</p>	<p style="text-align: center;">Option 1 2x Single 1505 x 725 (4' 11" x 2' 4") 2x Single 1930 x 865 max. (6' 4" x 2' 10")</p> <p style="text-align: center;">Option 2 1x Double 2200 x 1390 (7' 2" x 4' 7") 2x Single 1930 x 865 max. (6' 4" x 2' 10")</p>	<p style="text-align: center;">Option 1 2x Single 1505 x 725 (4' 11" x 2' 4") 1x Double 1875 x 1370 (6' 2" x 4' 6")</p> <p style="text-align: center;">Option 2 1x Double 2200 x 1390 (7' 2" x 4' 7") 1x Double 1875 x 1370 (6' 2" x 4' 6")</p>
MTPLM	1919kg	1898kg	1896kg
Mass in Running Order	1759kg	1738kg	1736kg
Personal Payload	160kg	160kg	160kg
Options Payload	0kg	0kg	0kg
Total / Maximum User Payload	160kg	160kg	160kg
Maximum Hitch Weight	100kg	100kg	100kg
Upper MTPLM (Optional weight plate upgrade)	2.4 / 35	2.4 / 35	2.4 / 35

Note:- Please consult your dealer for terms and conditions regarding a weight plate upgrade to the upper MTPLM. Any imperial measurement is given as a guide only and may be subject to rounding up/down.
 * Estimated weights. Please refer to the website for confirmed weights. ** Alternative tyres maybe fitted but will be of equivalent or higher load rating. Alternative would be 185/65 R14 93N

Laser dealer specials specifications (based on the models below)

MODEL	480 Xtra	545 Xtra	575 Xtra	845 Xtra
Number of Berths	2	4	4	4
Interior Length	4800mm / 15' 9"	5800mm / 19' 0"	5800mm / 19' 0"	6265mm / 20' 7"
Overall Length	6430mm / 21' 1"	7430mm / 24' 5"	7430mm / 24' 5"	7895mm / 25' 11"
Overall Width	2440mm / 8'	2440mm / 8'	2440mm / 8'	2440mm / 8'
Overall Height (including TV Aerial)	2675mm / 8' 9"	2675mm / 8' 9"	2675mm / 8' 9"	2675mm / 8' 9"
Overall Height (including Air Conditioner)	2750mm / 9'	2750mm / 9'	2750mm / 9'	2750mm / 9'
Maximum Headroom	1955mm / 6' 5"	1955mm / 6' 5"	1955mm / 6' 5"	1955mm / 6' 5"
Wheel Rim	6.0J x 15	6.0J x 15	6.0J x 15	5.5J x 14
Tyre Size	195/70 R15 104	205/70 R15 106	205/70 R15 106	185/70 R14 88
Tyre Pressure (bar / psi at quoted MTPLM)	4.5 / 65	4.5 / 65	4.5 / 65	2.4 / 35
Bed Sizes	<p>Option 1 2x Single 1840 x 725 (6' x 2' 4")</p> <p>Option 2 1x Double 2000 x 1390 (7' 2" x 4' 7")</p>	<p>Option 1 1x Single 1565 x 705 (5' 2" x 2' 4") 1x Single 1980 x 770 (6' 6" x 2' 6") 1x Double 1875 x 1425 (6' 2" x 4' 8")</p> <p>Option 2 1x Double 1980 x 1370 (6' 6" x 4' 6") 1x Double 1875 x 1425 (6' 2" x 4' 8")</p>	<p>Option 1 2x Single 1505 x 725 (4' 11" x 2' 4") 1x Double 1875 x 1370 (6' 2" x 4' 6")</p> <p>Option 2 1x Double 2200 x 1390 (7' 2" x 4' 7") 1x Double 1875 x 1370 (6' 2" x 4' 6")</p>	<p>Option 1 2x Single 1980 x 770 (6' 6" x 2' 6") 1720 x 705 (5' 7" x 2' 4") 1x Double 1875 x 1425 (6' 2" x 4' 8")</p> <p>Option 2 1x Double 1980 x 1370 (6' 6" x 4' 6") 1x Double 1875 x 1425 (6' 2" x 4' 8")</p>
MTPLM	1557kg	1777kg	1746kg	1926kg
Mass in Running Order	1432kg	1622kg	1591kg	1766kg
Personal Payload	125kg	155kg	155kg	160kg
Options Payload	0kg	0kg	0kg	0kg
Total / Maximum User Payload	125kg	155kg	155kg	160kg
Maximum Hitch Weight	100kg	100kg	100kg	100kg
Upper MTPLM (Optional weight plate upgrade)	1600kg	1800kg	1800kg	2000kg
Tyre Pressure (bar / psi at Upper MTPLM)	4.5 / 65	4.5 / 65	4.5 / 65	2.4 / 35

Note:- Please consult your dealer for terms and conditions regarding a weight plate upgrade to the upper MTPLM. Any imperial measurement is given as a guide only and may be subject to rounding up/down.
 * Estimated weights. Please refer to the website for confirmed weights. ** Alternative tyres maybe fitted but will be of equivalent or higher load rating. Alternative would be 185/65 R14 93N

Laser dealer specials specifications (based on the models below)

MODEL	855 Xtra	865 Xtra	875 Xtra
Number of Berths	4	4	4
Interior Length	6265mm / 20' 7"	6265mm / 20' 7"	6265mm / 20' 7"
Overall Length	7895mm / 25' 11"	7895mm / 25' 11"	7895mm / 25' 11"
Overall Width	2440mm / 8'	2440mm / 8'	2440mm / 8'
Overall Height (including TV Aerial)	2675mm / 8' 9"	2675mm / 8' 9"	2675mm / 8' 9"
Overall Height (including Air Conditioner)	2750mm / 9'	2750mm / 9'	2750mm / 9'
Maximum Headroom	1955mm / 6' 5"	1955mm / 6' 5"	1955mm / 6' 5"
Wheel Rim	5.5J x 14	5.5J x 14	5.5J x 14
Tyre Size	185/70 R14 88	185/70 R14 88	185/70 R14 88
Tyre Pressure (bar / psi at quoted MTPLM)	2.4 / 35	2.4 / 35	2.4 / 35
Bed Sizes	<p style="text-align: center;">Option 1 2x Single 1900 x 705 (6' 2" x 2' 3") 1980 x 770 (6' 6" x 2' 6") 1x Double 1875 x 1370 (6' 2" x 4' 6")</p> <p style="text-align: center;">Option 2 1x Double 1980 x 1370 (6' 6" x 4' 6") 1x Double 1875 x 1425 (6' 2" x 4' 8")</p>	<p style="text-align: center;">Option 1 2x Single 1505 x 725 (4' 11" x 2' 4") 2x Single 1930 x 865 max. (6' 4" x 2' 10")</p> <p style="text-align: center;">Option 2 1x Double 2200 x 1390 (7' 2" x 4' 7") 2x Single 1930 x 865 max. (6' 4" x 2' 10")</p>	<p style="text-align: center;">Option 1 2x Single 1505 x 725 (4' 11" x 2' 4") 1x Double 1875 x 1370 (6' 2" x 4' 6")</p> <p style="text-align: center;">Option 2 1x Double 2200 x 1390 (7' 2" x 4' 7") 1x Double 1875 x 1370 (6' 2" x 4' 6")</p>
MTPLM	1926kg	1905kg	1903kg
Mass in Running Order	1766kg	1745kg	1743kg
Personal Payload	160kg	160kg	160kg
Options Payload	0kg	0kg	0kg
Total / Maximum User Payload	160kg	160kg	160kg
Maximum Hitch Weight	100kg	100kg	100kg
Upper MTPLM (Optional weight plate upgrade)	2000kg	2000kg	2000kg
Tyre Pressure (bar / psi at Upper MTPLM)	2.4 / 35	2.4 / 35	2.4 / 35

Note:- Please consult your dealer for terms and conditions regarding a weight plate upgrade to the upper MTPLM. Any imperial measurement is given as a guide only and may be subject to rounding up/down.
* Estimated weights. Please refer to the website for confirmed weights. ** Alternative tyres may be fitted but will be of equivalent or higher load rating. Alternative would be 185/65 R14 93N

Lusso standard specifications

MODEL	Lusso I	Lusso II	Lusso III	Lusso IV
Number of Berths	4	4	4	4
Interior Length	5800mm / 19' 0"	6265mm / 20' 7"	6265mm / 20' 7"	6265mm / 20' 7"
Overall Length	7430mm / 24' 5"	7895mm / 25' 11"	7895mm / 25' 11"	7895mm / 25' 11"
Overall Width	2440mm / 8'	2440mm / 8'	2440mm / 8'	2440mm / 8'
Overall Height (including T.V Aerial)	2675mm / 8' 9"	2675mm / 8' 9"	2675mm / 8' 9"	2675mm / 8' 9"
Overall Height (including Air Conditioner)	2750mm / 9'	2750mm / 9'	2750mm / 9'	2750mm / 9'
Maximum Headroom	1955mm / 6' 5"	1955mm / 6' 5"	1955mm / 6' 5"	1955mm / 6' 5"
Wheel Rim	6.0J x 15	5.5J x 14	5.5J x 14	5.5J x 14
Tyre Size	205/70 R15 106	185/65 R14 93	185/65 R14 93	185/65 R14 93
Tyre Pressure (bar / psi at quoted MTPLM)	4.5 / 65	3.4 / 50	3.4 / 50	3.4 / 50
Bed Sizes	Option 1 1x Single 1565 x 705 (5' 2" x 2' 4") 1x Single 1980 x 770 (6' 6" x 2' 6") 1x Double 1875 x 1370 (6' 2" x 4' 6") Option 2 1x Double 1980 x 1370 (6' 6" x 4' 6") 1x Double 1875 x 1370 (6' 2" x 4' 6")	Option 1 2x Single 1980 x 770 (6' 6" x 2' 6") 1x Single 1775 x 705 (5' 10" x 2' 3") 1x Double 1875 x 1370 (6' 2" x 4' 6") Option 2 1x Double 1980 x 1370 (6' 6" x 4' 6") 1x Double 1875 x 1370 (6' 2" x 4' 6")	Option 1 2x Single 1980 x 770 (6' 6" x 2' 6") 1x Single 1775 x 705 (5' 10" x 2' 3") 2x Single 1925 x 800 (6' 3" x 2' 7") Option 2 1x Double 1980 x 1370 (6' 6" x 4' 6") 2x Single 1925 x 800 (6' 3" x 2' 7")	Option 1 2x Single 1980 x 770 (6' 6" x 2' 6") 1x Single 1775 x 705 (5' 10" x 2' 3") 1x Double 1875 x 1370 (6' 2" x 4' 6") Option 2 1x Double 1980 x 1370 (6' 6" x 4' 6") 1x Double 1875 x 1370 (6' 2" x 4' 6")
MTPLM	1871kg	2005kg	2011kg	2035kg
Mass in Running Order	1716kg	1845kg	1851kg	1875kg
Personal Payload	155kg	160kg	160kg	160kg
Options Payload	0kg	0kg	0kg	0kg
Total / Maximum User Payload	155kg	160kg	160kg	160kg
Maximum Hitch Weight	120kg	120kg	120kg	120kg
Upper MTPLM (Optional weight plate upgrade)	1900kg	2200kg	2200kg	2200kg
Tyre Pressure (bar / psi at Upper MTPLM)	4.5 / 65	3.4 / 50	3.4 / 50	3.4 / 50

Note:- Please consult your dealer for terms and conditions regarding a weight plate upgrade to the upper MTPLM. Any imperial measurement is given as a guide only and may be subject to rounding up/down.
 * Estimated weights. Please refer to the website for confirmed weights. ** Alternative tyres maybe fitted but will be of equivalent or higher load rating. Alternative would be 185/65 R14 93N

Index

A		Water	35	Maintenance	154	T	
Alde Heating	64	Gas	40	Wheel Changing	29	Television Aerial	133
AL-KO Chassis	154	Electricity	44	Wheels & Tyres	156	Towing Code	11
Arrival at Site	32	Consumer Unit	47	Microwave	114	Towing & Driving	28
Parking	34	Control Panel	53			Pulling Off	28
Selecting a Pitch	33	Coupling-Up Checklist	28	O		Reversing	29
Unhitching	33			Oven, Hob, Grill	100	Speed Limits	28
Levelling	33	E					
Aventa Air Conditioning Unit	71	Electricity	44	P		V	
		Wiring of Connecting Cable & Caravan Mains Inlet	46	Preparing for the Road	16	Ventilation	32
		Fuses	49	Pre-Tow Checklist & Hitch-up	17	VIN	5
B		Relay Housing	49	Pressurised Water System	35	W	
Battery	50	Testing RCD	49			Warranty	159
Beds & Bunks	143	Polarity	49	R		Water System	35
Blinds & Flyscreens	130	G		Refrigerator Operation	81	Connection	36
Braking System	10	Gas	40	Rooflights	126	Wheel Changing	29
Breakaway Cable	16	The Regulator	41	Omnivent 12V Rooflight	126	Wi-Fi	144
		Types of Gas	41	Micro, Midi & Mini Heki Rooflight	128		
		Gas Barbecue Point	131	S			
C				Safety & Security	31		
Caravan Equipment	64	H		Servicing	158		
Caravan Handling	28	Heating System	64	Smoke Alarm	115		
Caravan Mains Inlet	46	M		Stabiliser	19		
Caravan Registration & Identification Scheme (VIN)	5			Storage	152		
Charger	47						
Cleaning	144						
Connecting Services	35						

CHANGE OF OWNERSHIP

NOTIFICATION OF CHANGE OF OWNERSHIP

If you buy this caravan as a used unit, please supply the change of ownership by emailing aftercare@coachman.co.uk with the following information. **This must be completed within 28 days of change of ownership:**

Model:

Vehicle Identification Number:

New Owner

Name:

Address:

Telephone Number(s):

Email:

Post Code:

Date of Purchase:

Please note that the benefit of any unexpired warranty cannot be transferred to the new owner until change of ownership details above together with a payment of £50.00 have been received. Bank details will be provided by return email.

All personal details submitted above will be kept private & confidential.

You can read our full privacy policy on our website www.coachman.co.uk/privacy-policy

As the new owner of a Coachman Caravan we would like to send you occasional marketing information on our products, services and events. If you would like to receive this information, please tick the appropriate boxes below. - Note: This is for the new owner, not the current owner.

I would like Coachman Caravans to send me marketing information via:

 Phone Email Text Post



COACHMAN

Coachman Caravan Company Ltd

Amsterdam Road
 Sutton Fields Industrial Estate
 Hull
 HU7 0XF
 Email: info@coachman.co.uk

www.coachman.co.uk

Coachman Caravan Company Limited reserves the right to, and does from time to time alter technical specifications, prices and model ranges as materials, model improvements and conditions demand. Therefore can accept no responsibility for discrepancies between these and subsequent models.

All Coachman models have been certified by the National Caravan Council for compliance with stringent European Standards, British Legislation and industry set Codes of Practice, specifically relating to health and safety issues. The approval process covers the testing and inspection of critical areas of the product from fire safety, weights and dimensions to gas, electrics and ventilation.

Every Coachman caravan carries the "NCC Approved Caravan" badge. The NCC also conducts unannounced inspections at the Coachman factory to ensure continued compliance. NCC Approval gives you peace of mind that your caravan is legal and safe.

Please note: Touring caravans are designated by the model year. The model year runs from the 1st September to the 31st August.